



**Life Time Friendly  
Customer Service**

844-627-4480

ProductSupport@  
rushcreekcreations.com



All Rush Creek Creations products have a 90-day from date of purchase warranty. This warrants the retail purchaser for any Rush Creek Creations product purchased to be free from any defect in materials and construction for 90 days from the date of purchase.

**Manufacturer Defects:** Defective parts will be replaced at no cost to you. Please send an e-mail to [productsupport@rushcreekcreations.com](mailto:productsupport@rushcreekcreations.com) including photos of the defective part(s), the name of your retailer, and your shipping address and we will send replacements.

Not Satisfied? – Let us know! We are here for you, REAL people in Milwaukee, WI. We hunt and fish and use our products and we stand by them. Reach out to us or email us, we want to help.



**Service à la clientèle  
pratique et toujours  
disponible**

844-627-4480

ProductSupport@  
rushcreekcreations.com



Tous les produits Rush Creek Creations sont couverts par une garantie de 90 jours à partir de la date d'achat. Celle-ci garantit à l'acheteur au détail que les produits Rush Creek Creations sont exempts de tout défaut de matériaux et de construction pendant 90 jours à partir de la date d'achat.

**Défauts dus au fabricant :** Les pièces défectueuses seront remplacées gratuitement. Veuillez envoyer un courriel à [ProductSupport@rushcreekcreations.com](mailto:ProductSupport@rushcreekcreations.com) en incluant des photos de la ou des pièces défectueuses et le nom de votre revendeur, et nous vous enverrons les pièces de remplacement.

Vous n'êtes pas satisfait? – Faites-le-nous savoir! Nous sommes là pour vous, et nous sommes de VRAIES personnes, à Milwaukee (Wisconsin). Nous chassons et pêchons, nous utilisons nos produits et nous les accompagnons de notre assistance. Joignez-nous ou envoyez-nous un courriel. Nous voulons vous aider.



**Servicio de atención  
al cliente amigable  
de por vida**

844-627-4480

ProductSupport@  
rushcreekcreations.com



Todos los productos de Rush Creek Creations tienen una garantía de 90 días a partir de la fecha de compra. Esto garantiza que el comprador minorista de productos de Rush Creek Creations adquiera productos sin defectos de materiales y construcción y que esté cubierto durante 90 días a partir de la fecha de compra.

**Defectos de fábrica:** Las piezas defectuosas se reemplazarán sin costo alguno. Envíe un correo electrónico a [ProductSupport@rushcreekcreations.com](mailto:ProductSupport@rushcreekcreations.com) con fotos de las piezas defectuosas, el nombre de la tienda minorista y la dirección de envío para que podamos mandarle los repuestos.

¿No está conforme? ¡Infórmenoslo! Estamos aquí para ayudarlo: personas REALES en Milwaukee, Wisconsin. Nosotros mismos usamos nuestros productos de caza y pesca, y los aprobamos. Si necesita ayuda, llámenos o envíenos un correo electrónico.

## No Limits 14-rod Track Storage System Aucune limite-14 système de stockage de cannes à pêche Sin límites-14 Sistema de almacenamiento de cañas de pescar

Item # / Article n° / Artículo N.º

40-0015

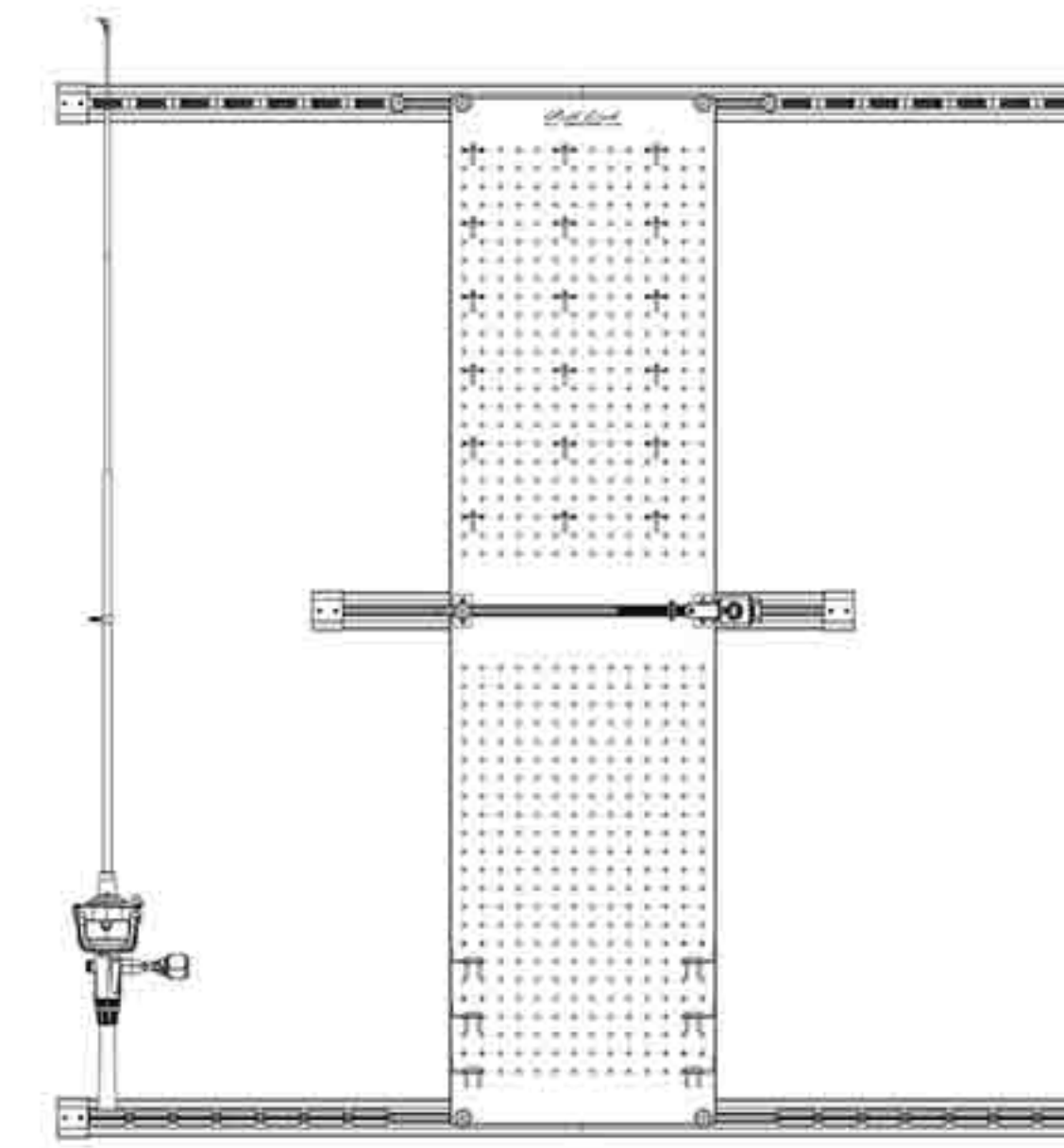

Install  
options

Options  
d'installation

Opciones  
de instalación

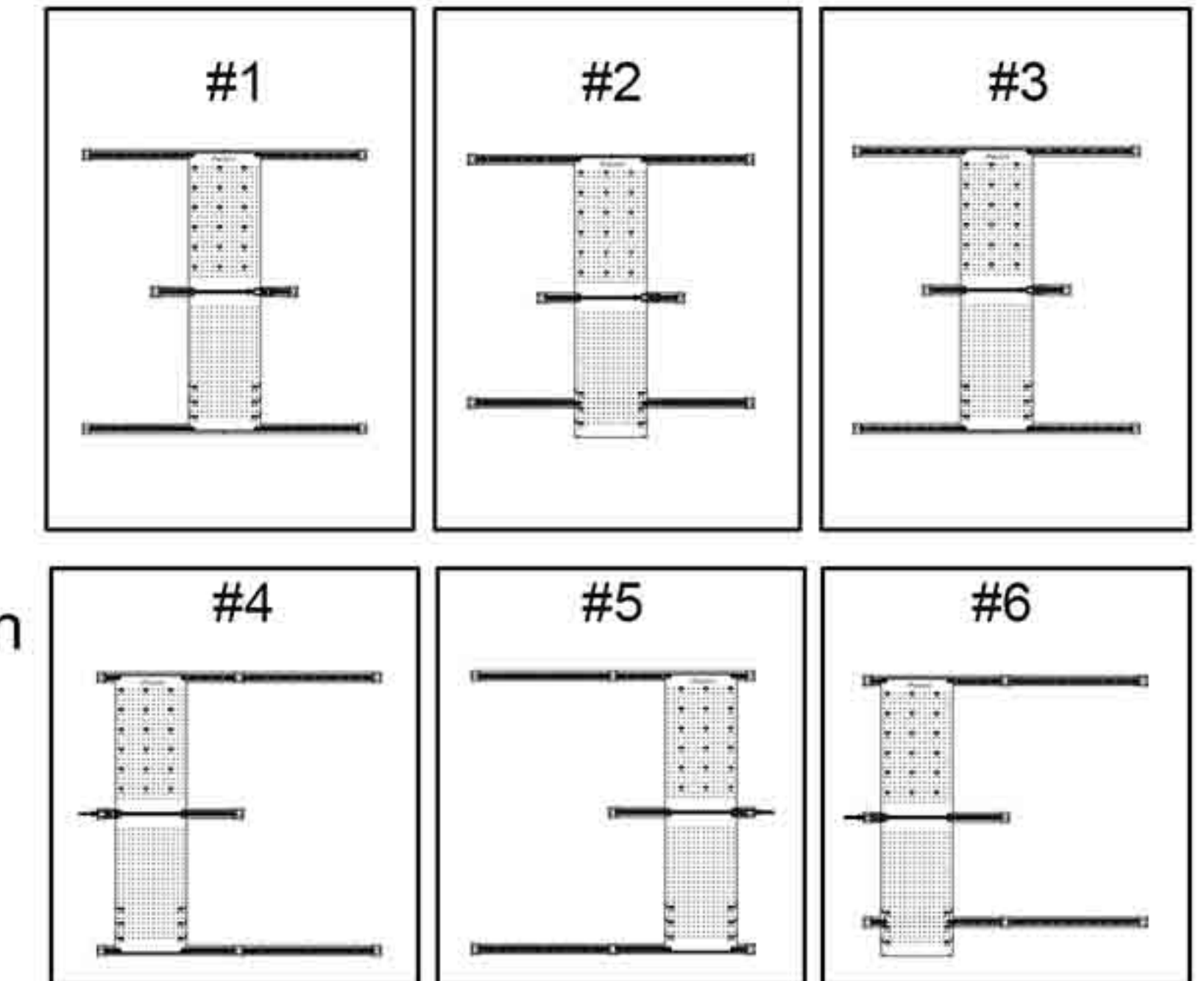

**Please keep this instruction manual for future reference**

Veillez conserver ce manuel d'instructions pour consultation future  
Conserve este manual de instrucciones para consultarlo en el futuro

**TECHNICAL SUPPORT OR REPLACEMENT PARTS  
ASSISTANCE TECHNIQUE OU PIÈCES DE REMPLACEMENT  
ASISTENCIA TÉCNICA O REPUESTOS**

**CONTACT INFO COORDONNÉES INFORMACIÓN DE CONTACTO**

Hours / Heures / Horario

Monday - Friday / Du lundi au vendredi / De lunes a viernes

(9:00am to 5:00pm CST) / (de 9 h 00 à 17 h 00, HNC) / (de 9:00 a 17:00, CST)

Email us at: / Envoyez-nous un courriel à l'adresse: / Correo electrónico: [productsupport@rushcreekcreations.com](mailto:productsupport@rushcreekcreations.com)

Visit us at: / Consultez notre site Web: / Sitio web:

[www.rushcreekcreations.com](http://www.rushcreekcreations.com)

Call us at: / Appelez-nous au: / Teléfono:

1-844-627-4480

For all replacement part needs: Please visit us at [www.rushcreekcreations.com](http://www.rushcreekcreations.com), click on CONTACT US and complete all required fields (all fields with asterisks must be completed before submitting)









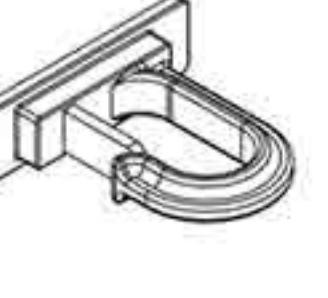
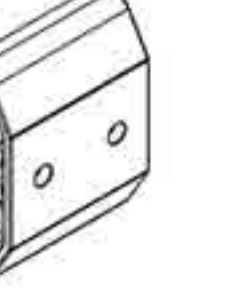
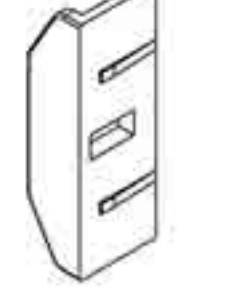

You will receive a response within 48 hours.

Pour tous les besoins de pièces de remplacement: Veuillez consulter notre site Web [www.rushcreekcreations.com](http://www.rushcreekcreations.com), cliquez sur COMMUNIQUEZ AVEC NOUS et remplissez tous les champs obligatoires (tous les champs avec astérisques doivent être remplis avant l'envoi). Vous recevrez une réponse dans les 48 heures.

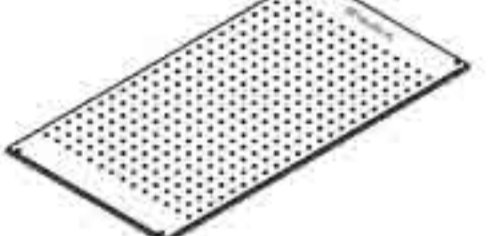
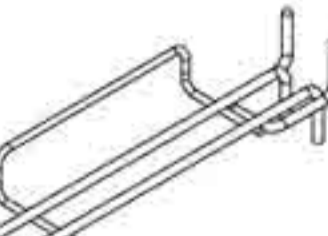
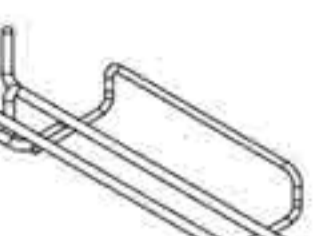
Si necesita repuestos: visítenos en [www.rushcreekcreations.com](http://www.rushcreekcreations.com), haga clic en "CONTACT US" y complete todos los campos obligatorios (debe completar todos los campos con asteriscos antes de enviar el formulario). Recibirá una respuesta en menos de 48 horas.

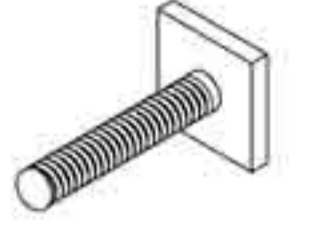

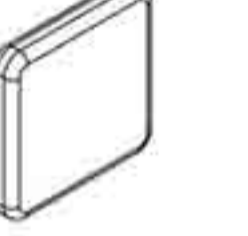
# Parts List / Liste des pieces / Lista de partes

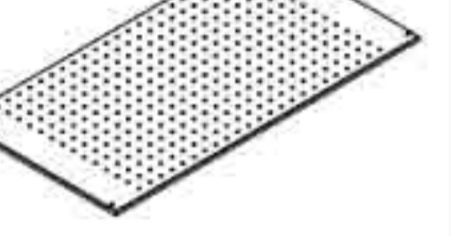
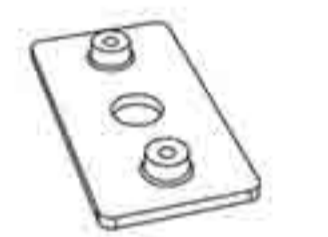
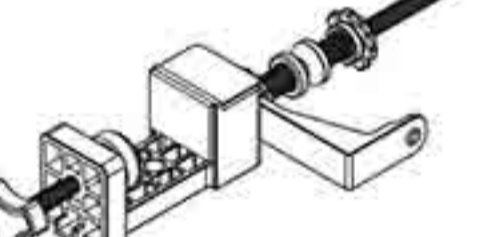
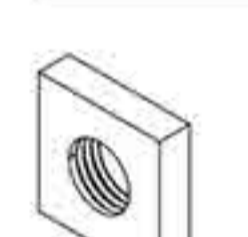
1  x5	2  x14	3  x14	4  x14	5  x8	6  x8
7  x10	8  x1	9  x3	10  x3	11  x18	12  x9
13  x9	14  x9	15  x10	16  2 Spare 2 pièces de rechange 2 repuestos x10+2	17  2 Spare 2 pièces de rechange 2 repuestos x10+2	18  x1
19  x2	20  x1	21  8 Pre-Assembled 8 Pré-assemblé 8 Pre-montado x2+8			

## Install option-1 / Option d'installation-1 / Opción de instalación-1

Drill the mounting holes in the wall according to the diagram 1.

percer les trous de montage dans le mur selon le diagramme 1.

perforar los orificios de montaje en la pared de acuerdo con el diagrama 1.

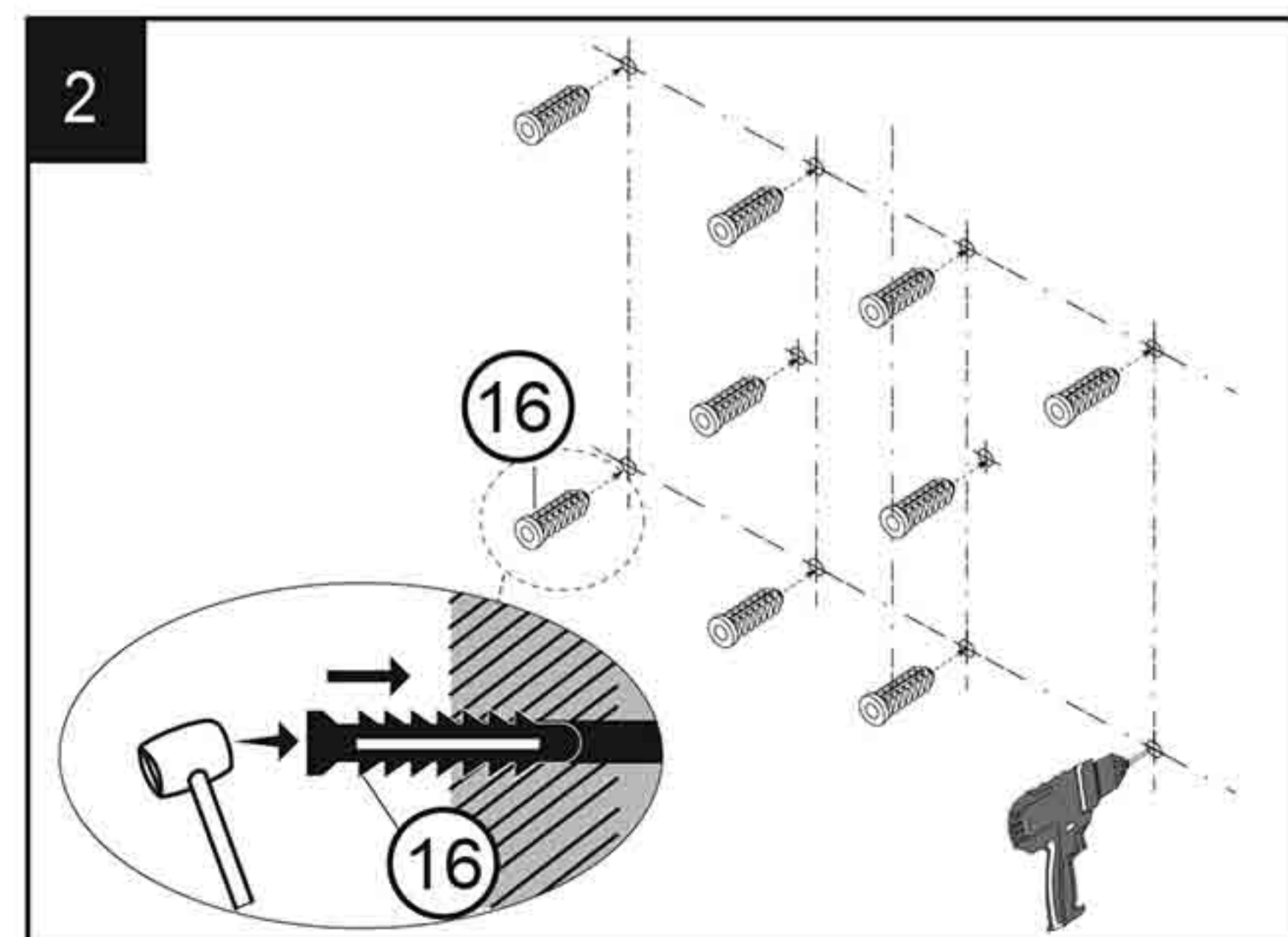
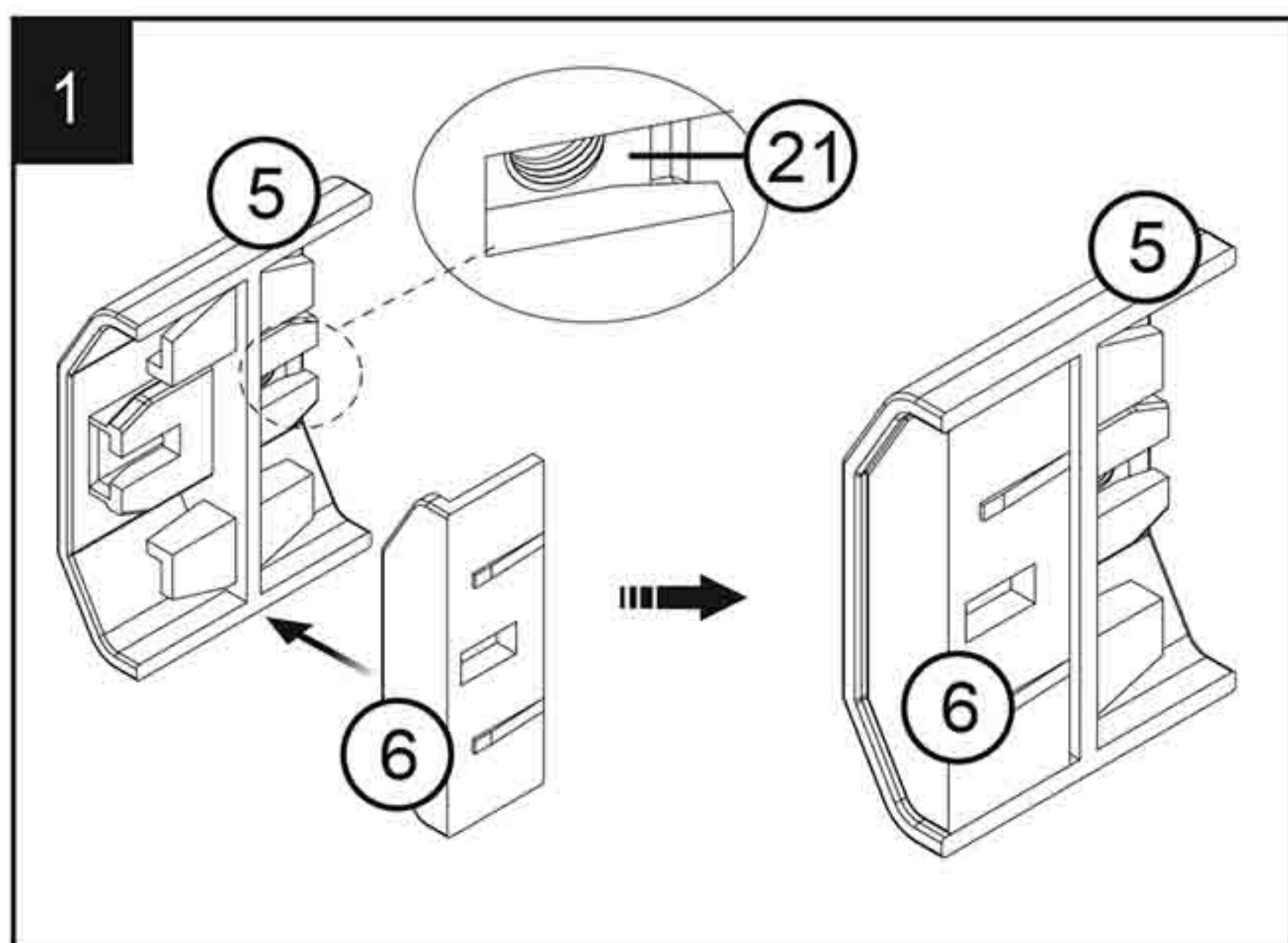
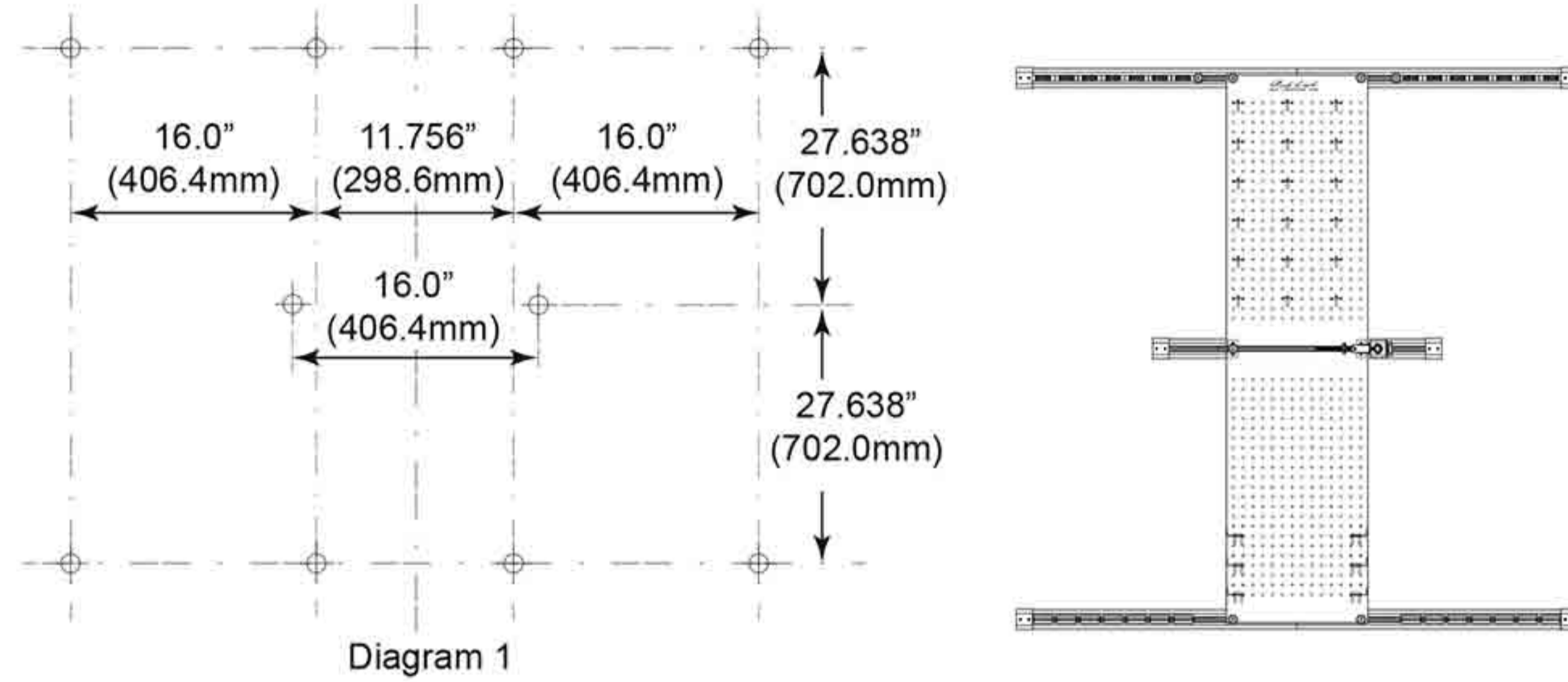

1

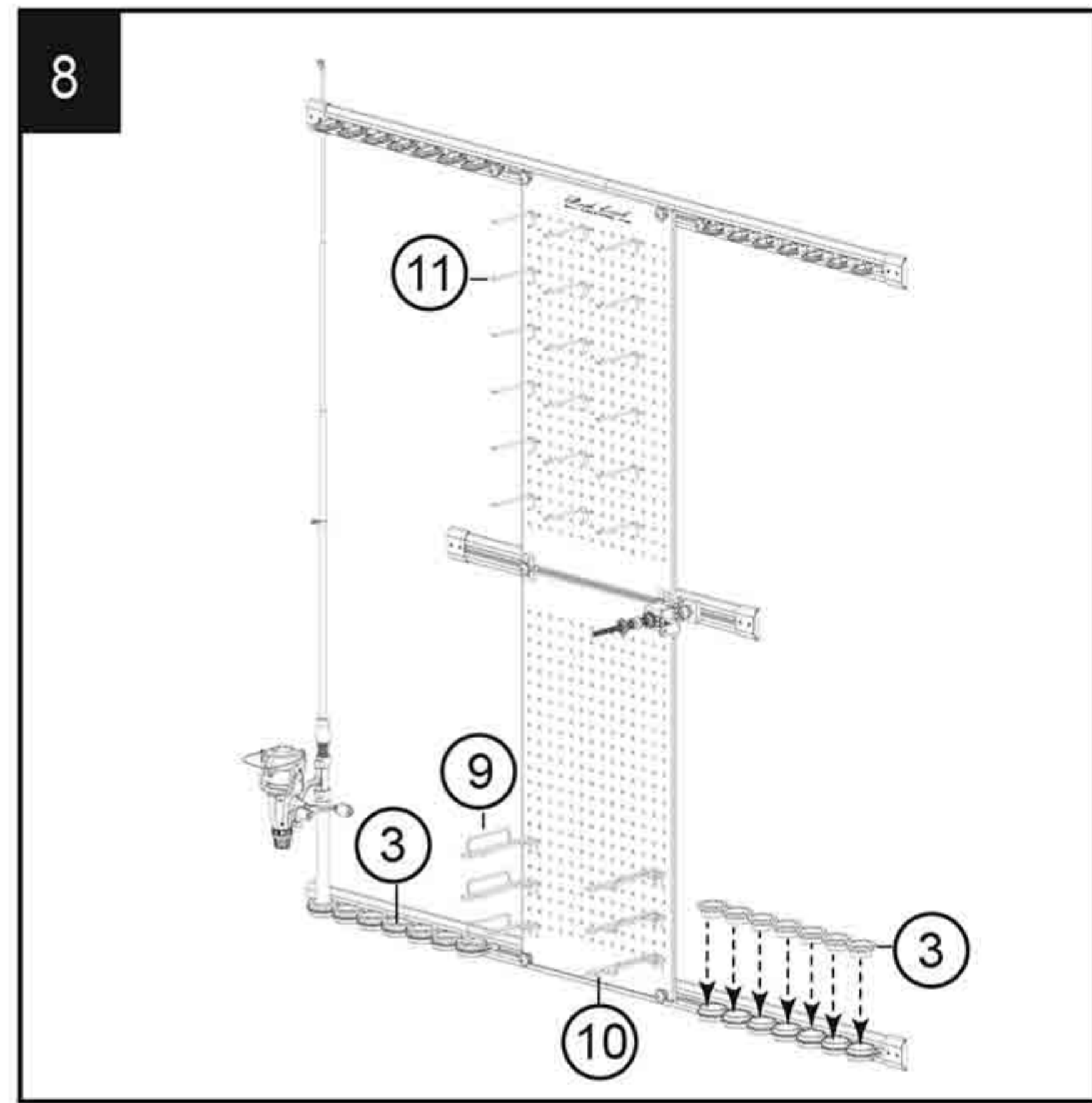
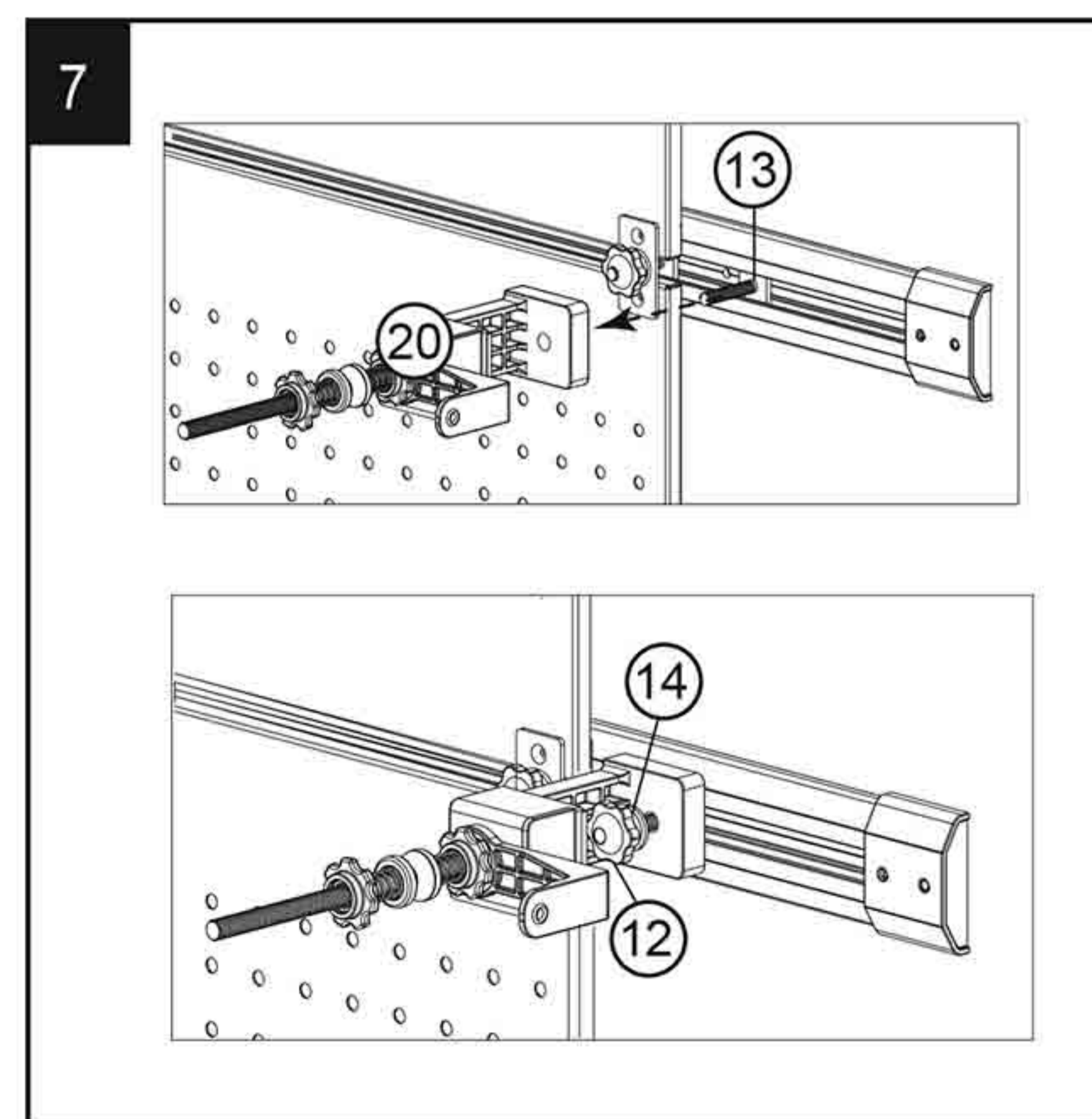
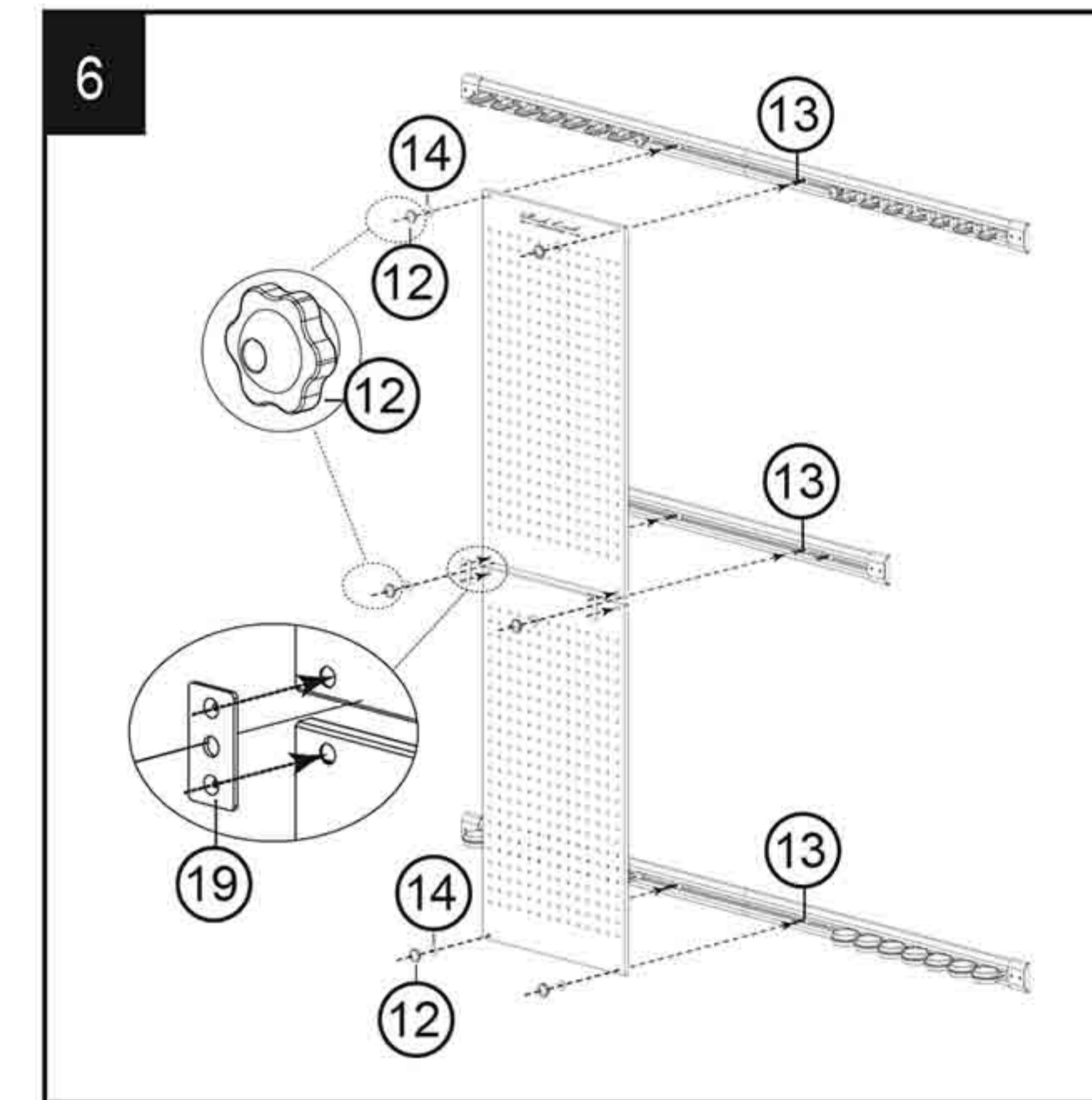
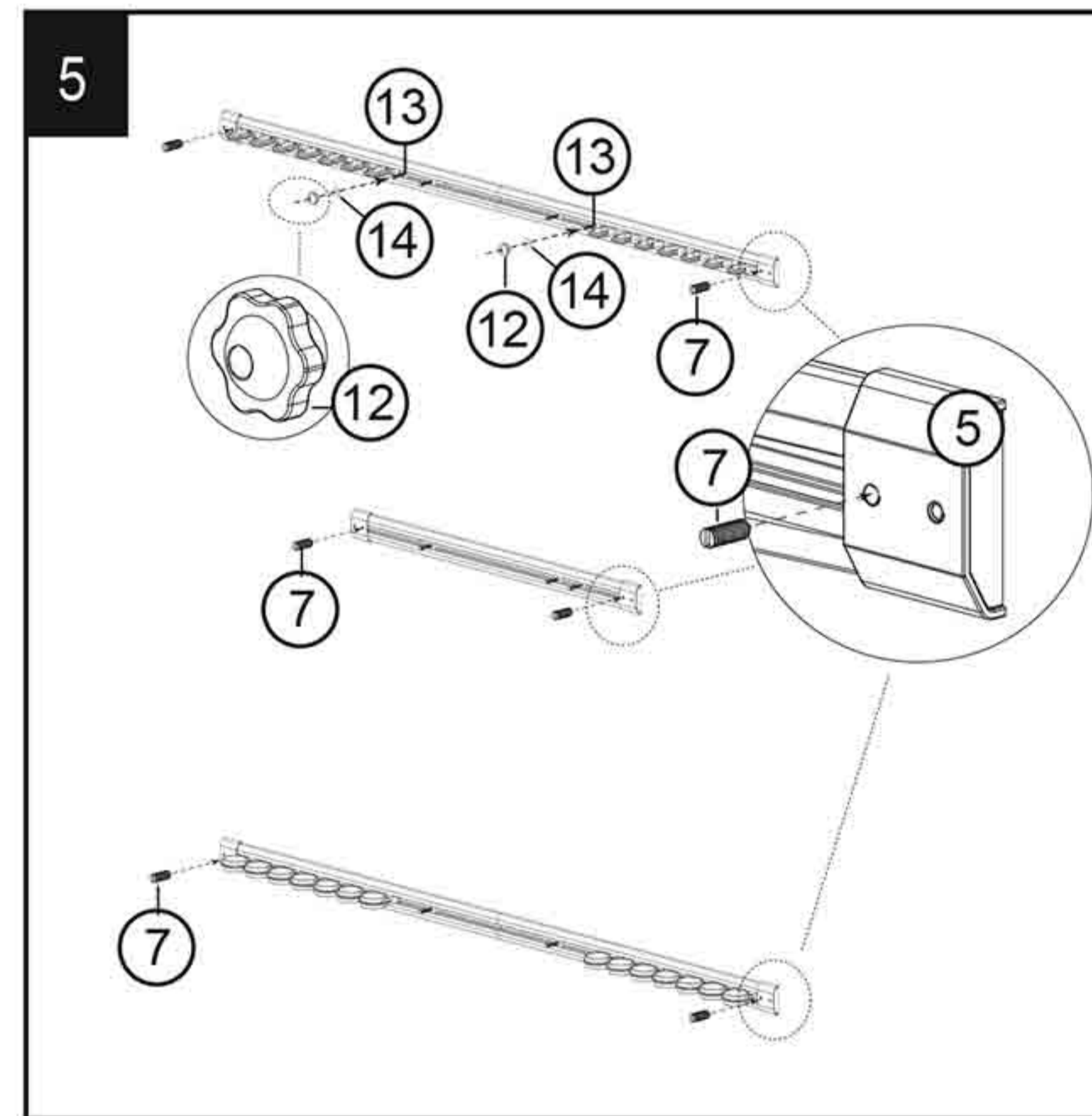
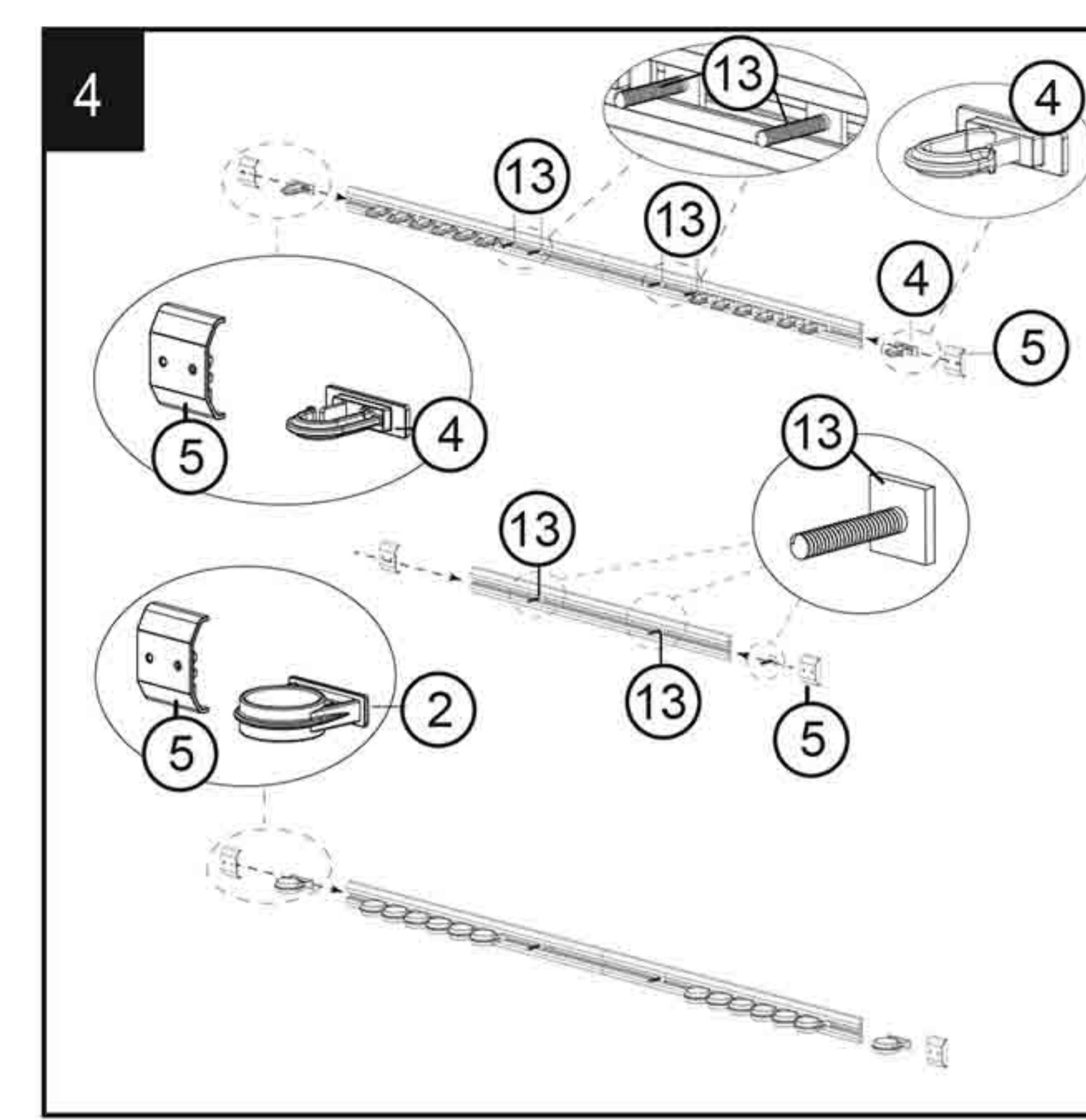
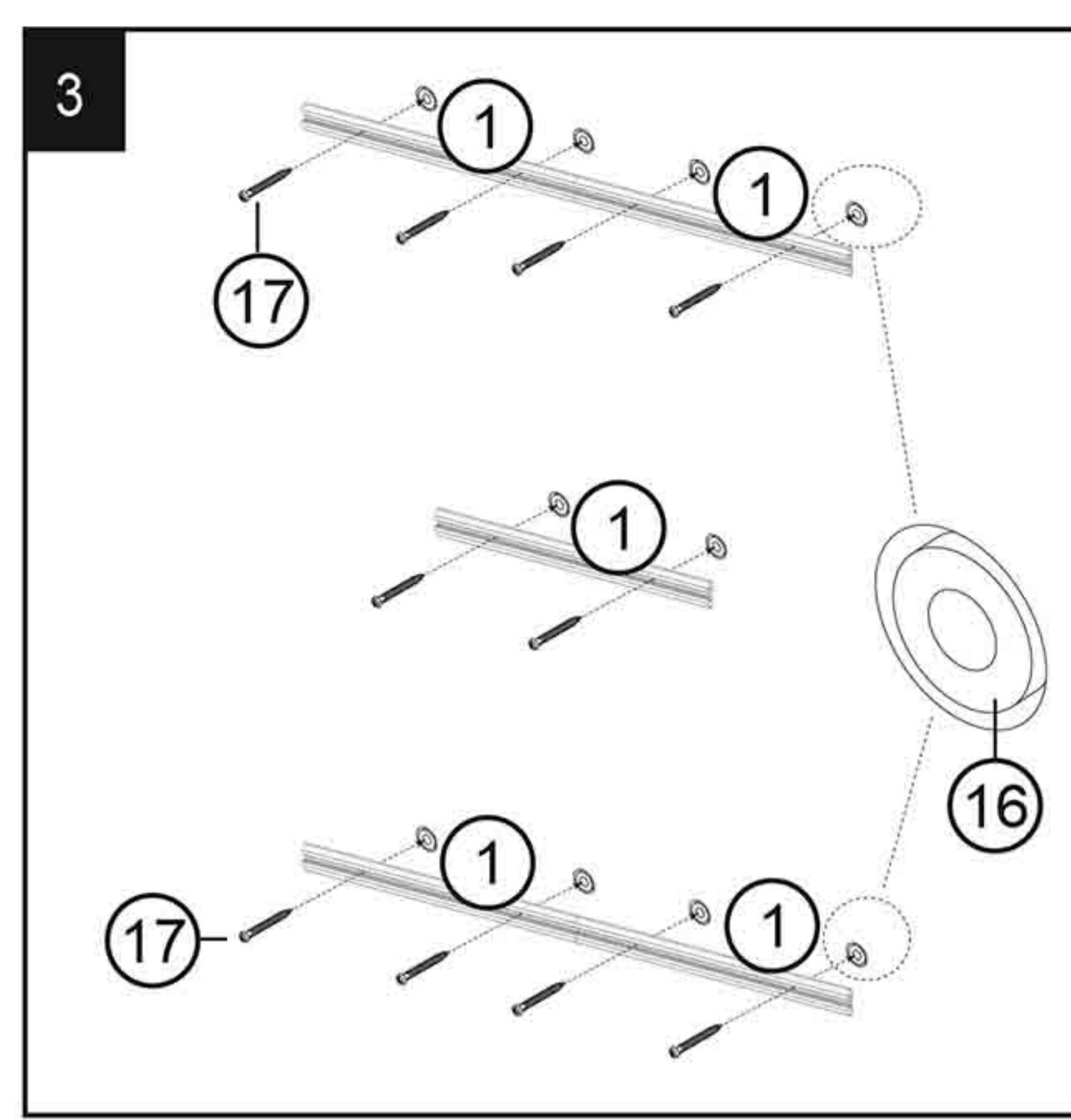

2



Install option-2 / Option d'installation-2 / Opción de instalación-2

Drill the mounting holes in the wall according to the diagram 2. Refer to Option 1- steps 1, 2, 3, 4, 5, 7, 8. For Step 6: Attach bottom peg board (#18) on the plastic channel (#1) with 2 M6 square head bolts (#13) go through peg hook holes.

Perçer les trous de montage dans le mur selon le diagramme 2. Référez-vous à l'option 1 - étapes 1, 2, 3, 4, 5, 7, 8. Étape 6: Fixez le panneau de cheville inférieur (#18) sur le canal en plastique (#1) avec 2 boulons de tête carrés M6 (#13) passez par des trous de crochet de cheville.

Perforar los orificios de montaje en la pared de acuerdo con el diagrama 2. Consulte la opción 1: pasos 1, 2, 3, 4, 5, 7, 8. Paso 6: Coloque la placa de clavija inferior (#18) en el canal de plástico con 2 pernos de cabeza cuadrada M6 (#13) pase por los orificios del gancho de clavijas.

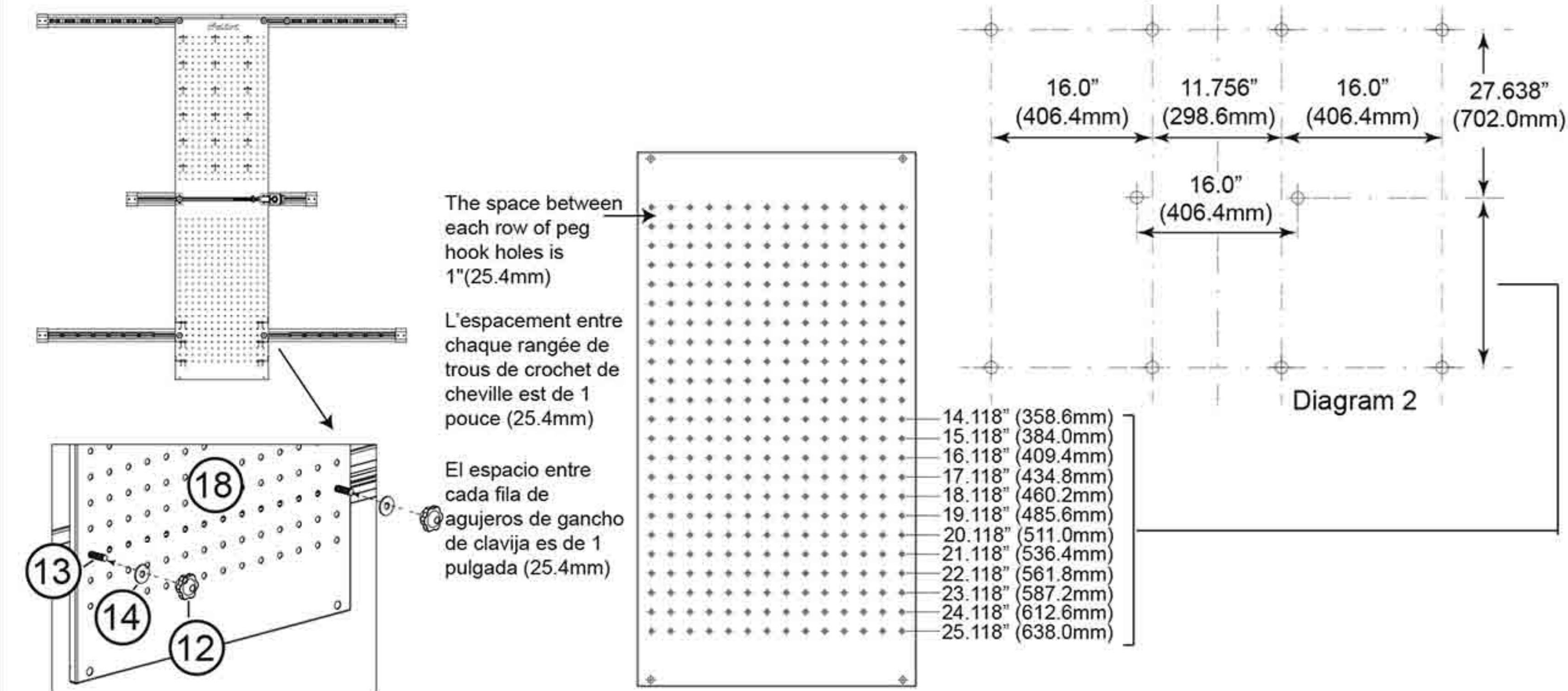

Install option-3 / Option d'installation-3 / Opción de instalación-3

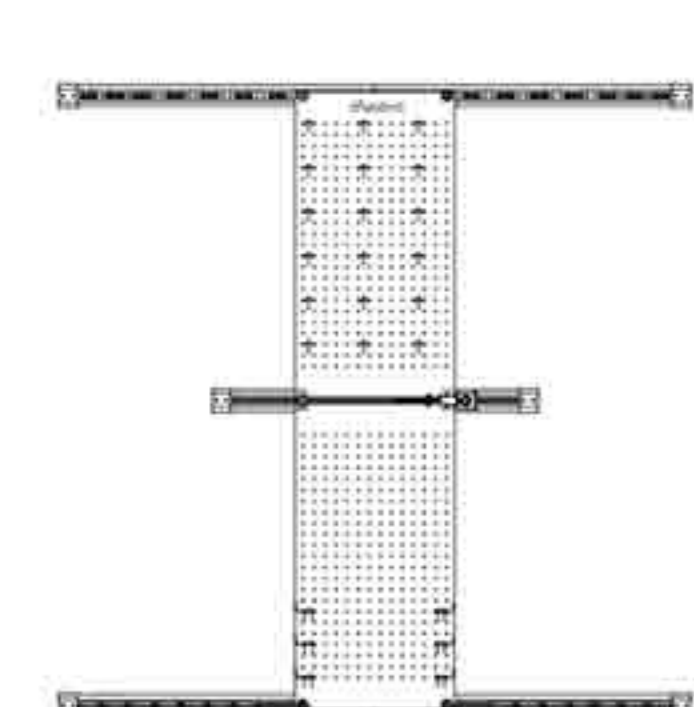

Installation option #3 is similar to #1. Refer to Option 1- steps 1, 2, 3, 5, 6, 7, 8. Step 4: Insert spacer (#15) between each J clips as shown in the diagram below to customize the spacing between rods. Note: Do Not insert M6 square head bolts (#13) to the top channel (#1) for this option.

L'option d'installation #3 est similaire à #1. Référez-vous à l'option 1 - étapes 1, 2, 3, 5, 6, 7, 8. Étape 4: Insérez l'entretoise (#15) entre chaque clips J comme indiqué dans le diagramme ci-dessous pour personnaliser l'espacement entre les tiges. Remarque: N'insérez pas de boulons de tête carrés M6 (#13) sur le canal supérieur (#1) pour cette option.

La opción de instalación #3 es similar a #1. Consulte la Opción 1: pasos 1, 2, 3, 5, 6, 7, 8. Paso 4: Inserte el espaciador (#15) entre cada clip J como se muestra en el diagrama a continuación para personalizar el espaciado entre varillas. Nota: No inserte pernos de cabeza cuadrada M6 (#13) en el canal superior para esta opción.

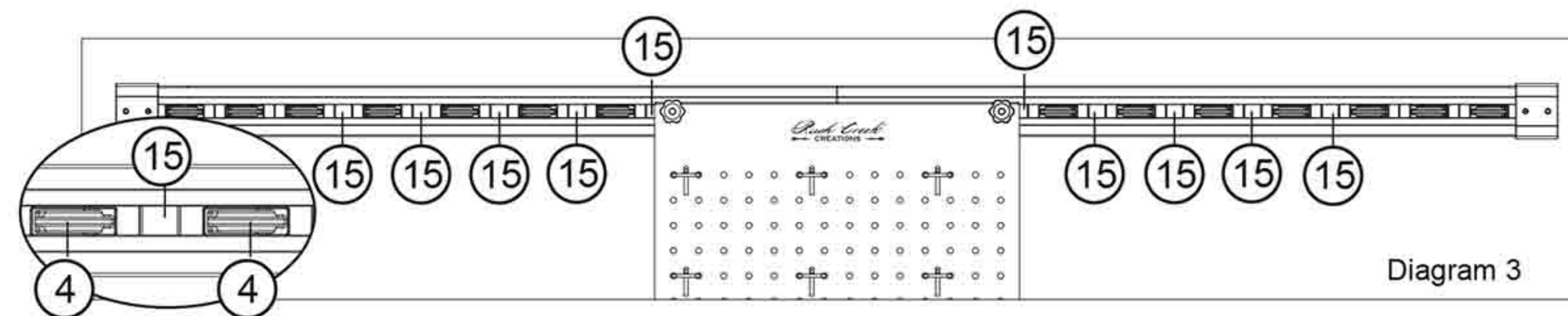

Install option-4 / Option d'installation-4 / Opción de instalación-4

1 Drill the mounting holes in the wall according to the diagram 4.

Perçer les trous de montage dans le mur selon le diagramme 4.

Perforar los orificios de montaje en la pared de acuerdo con el diagrama 4.

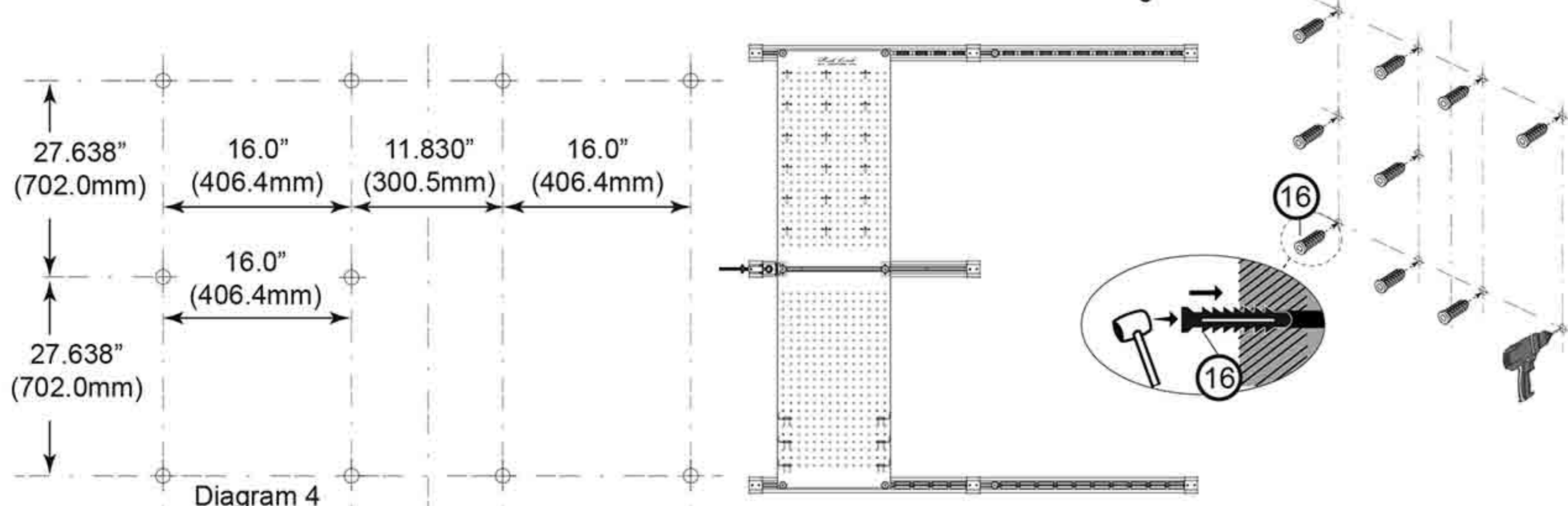

2

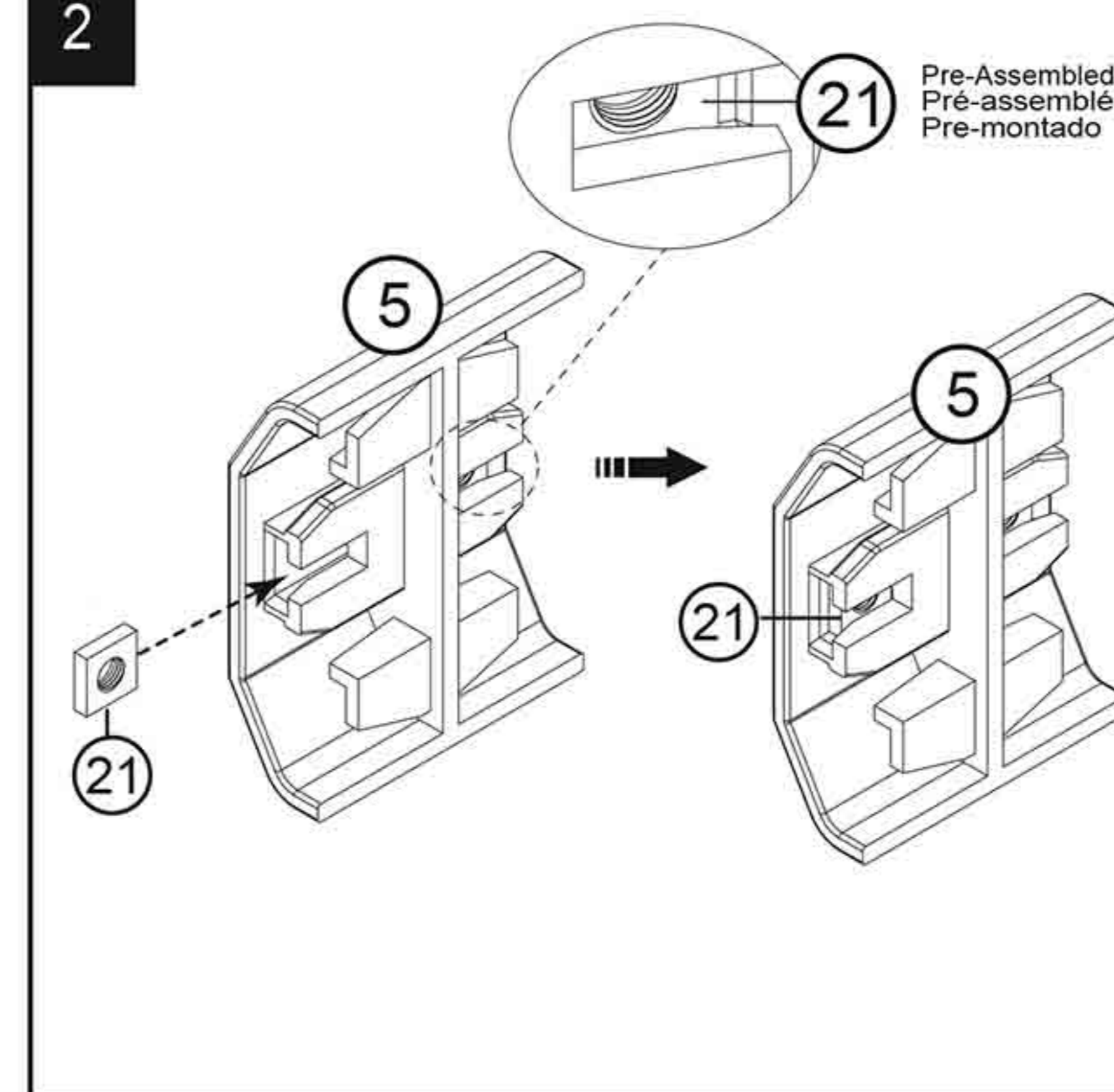

3

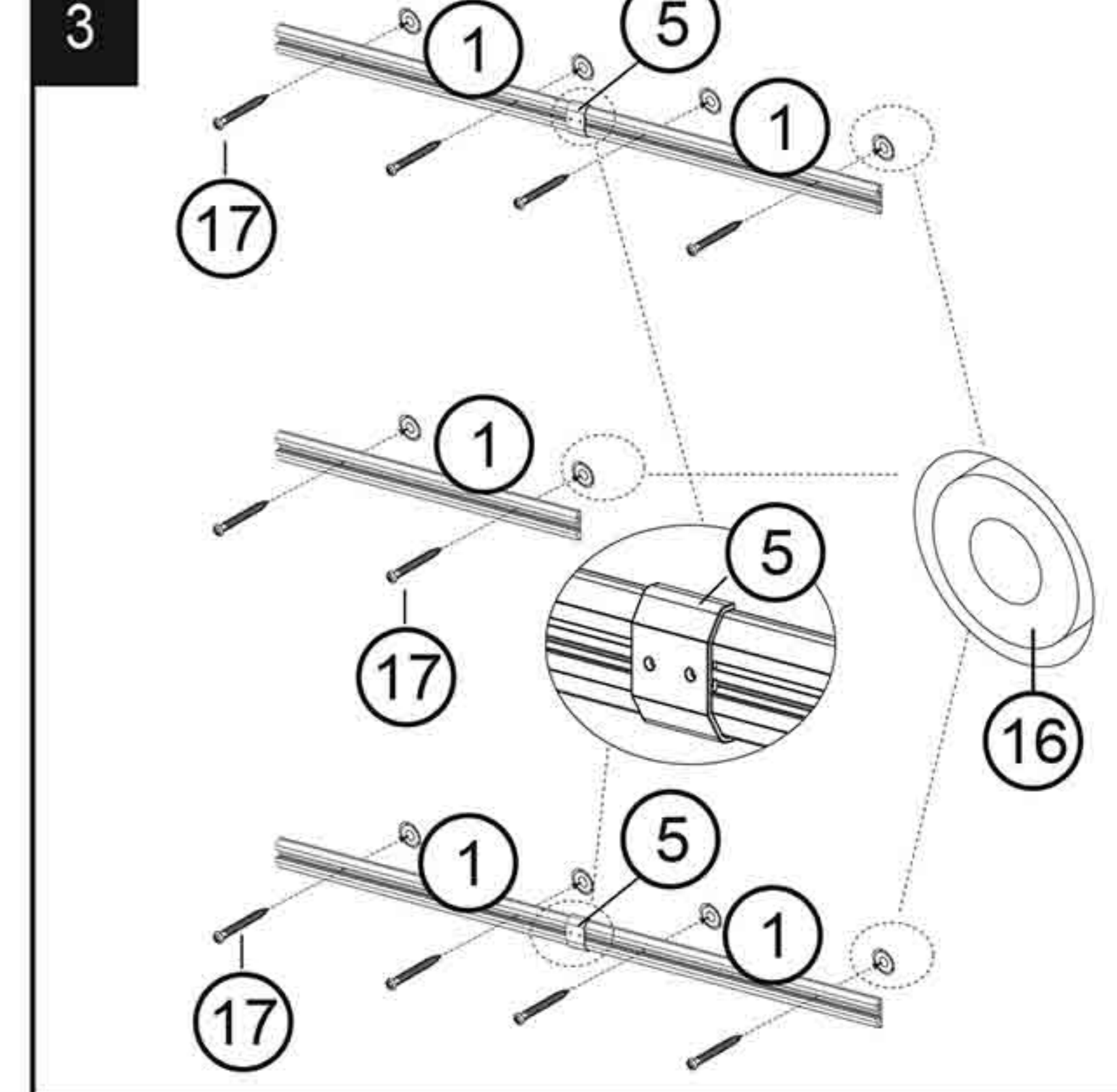

4

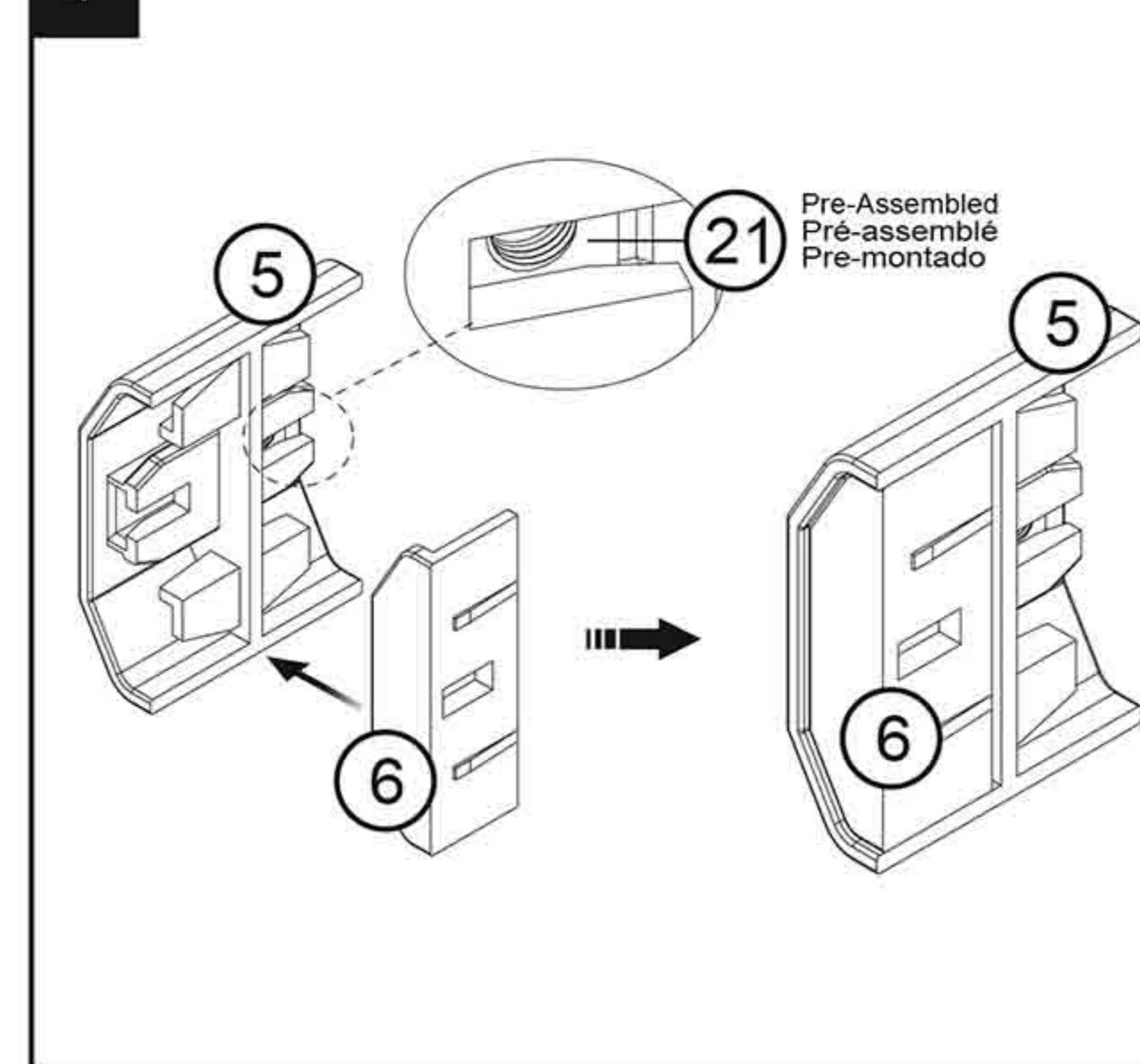

5

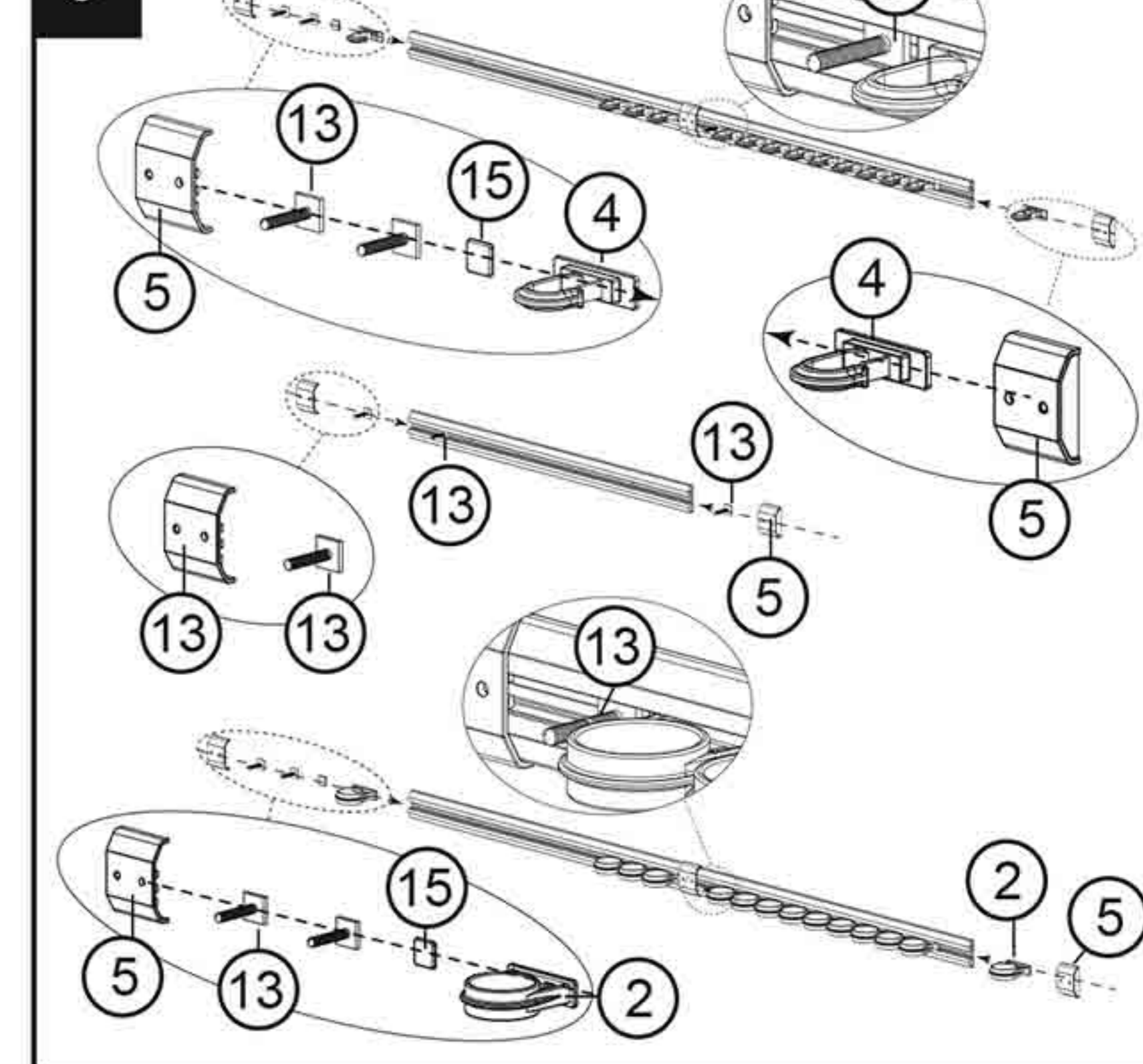

6

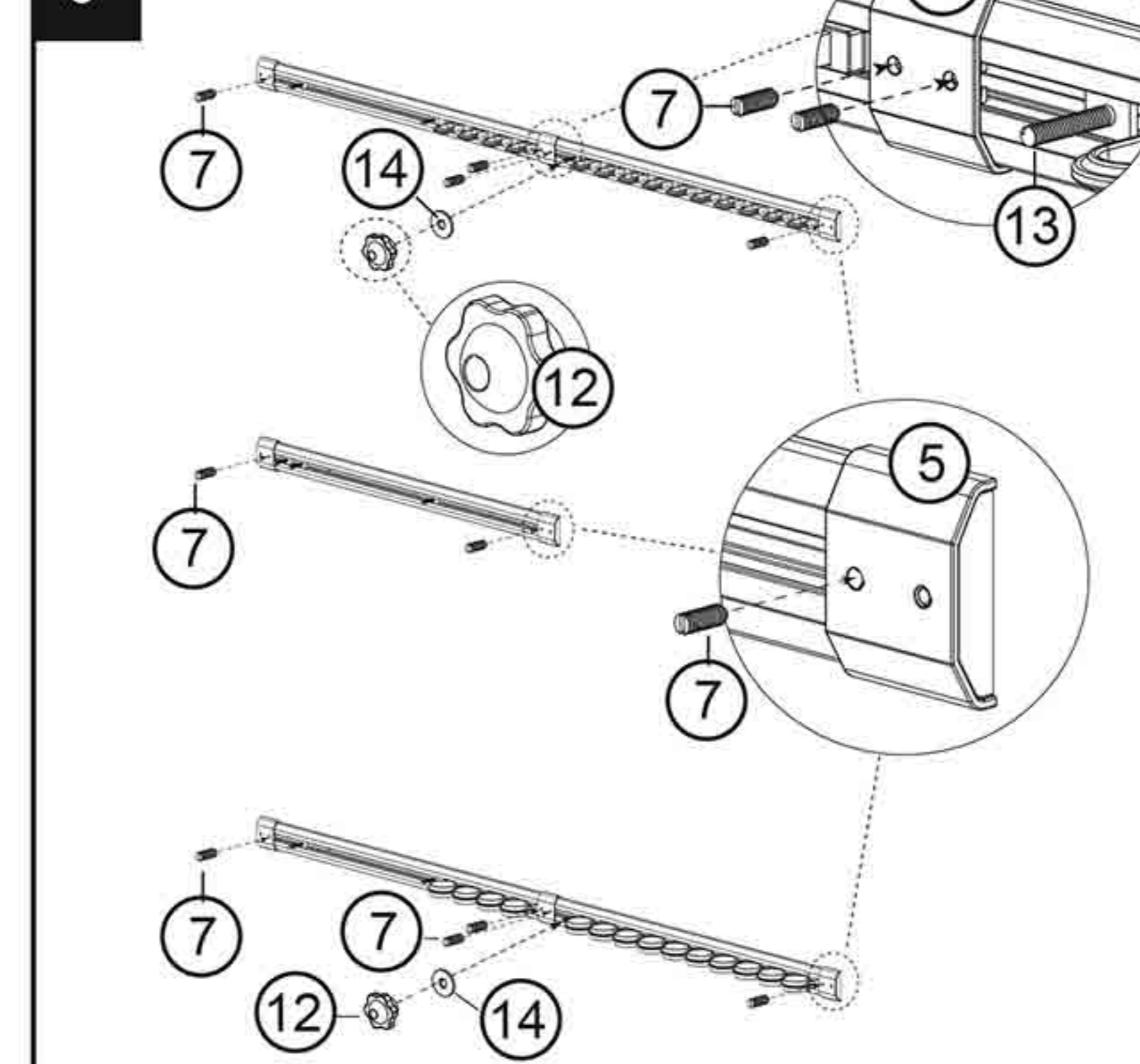

7

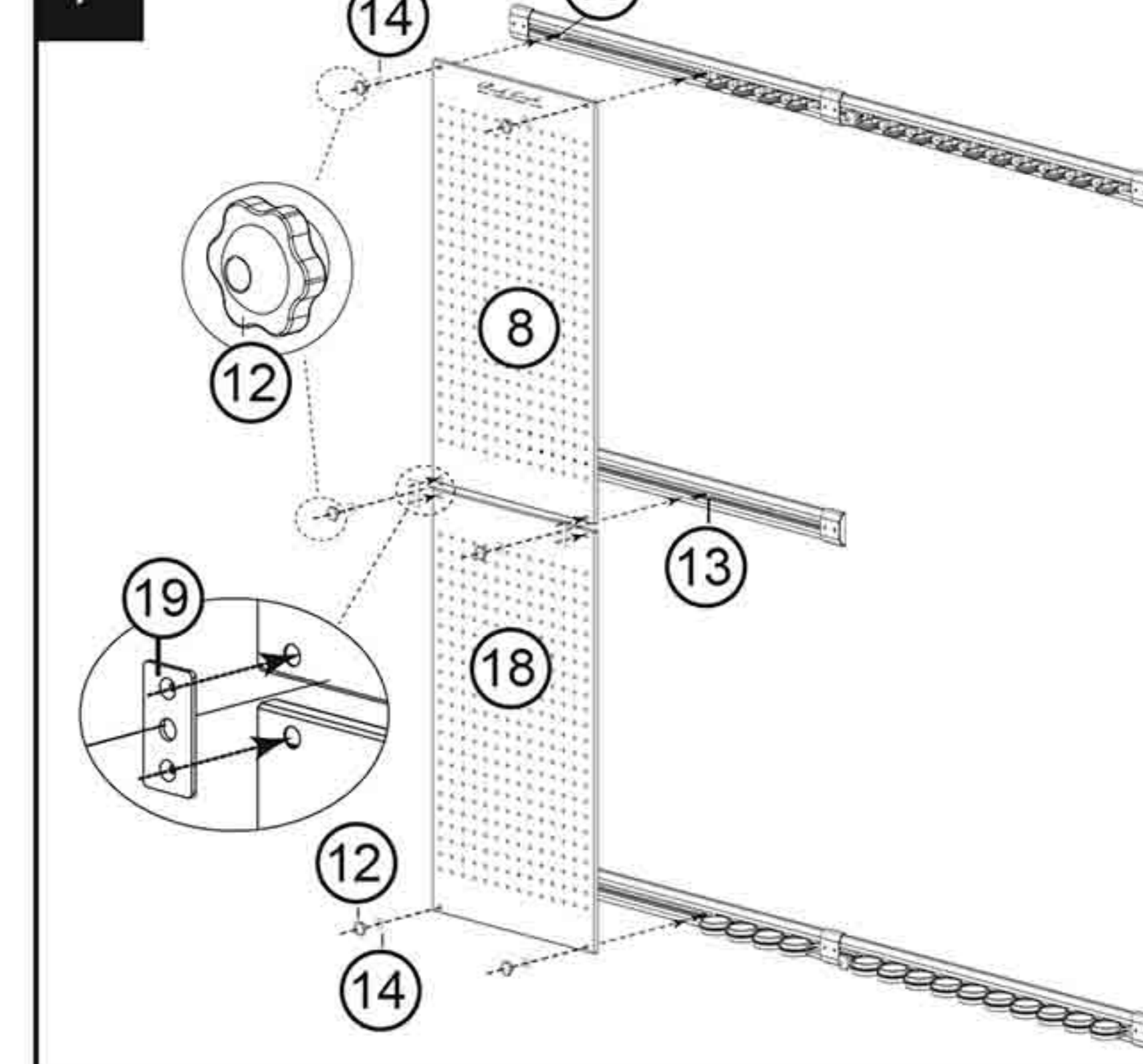



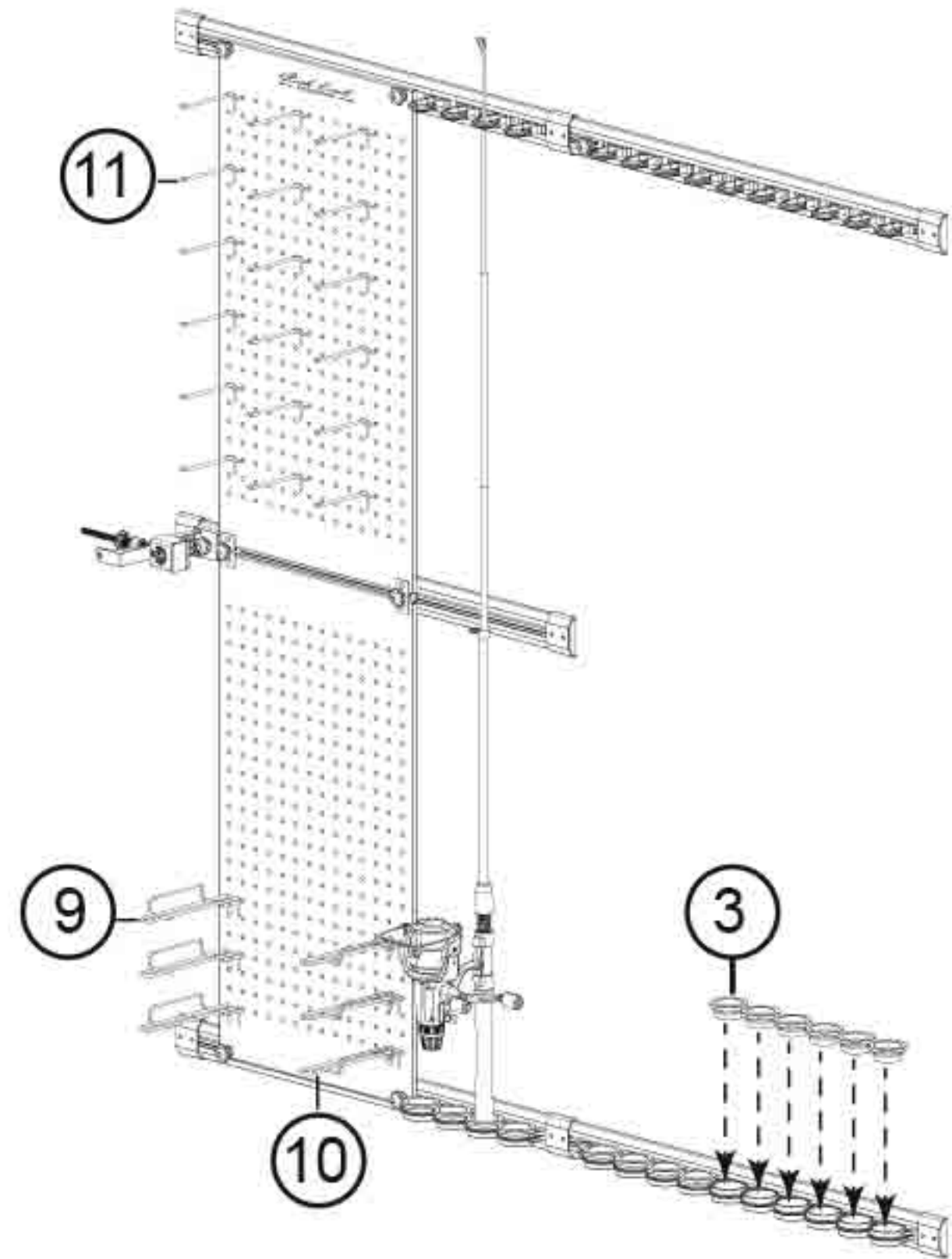
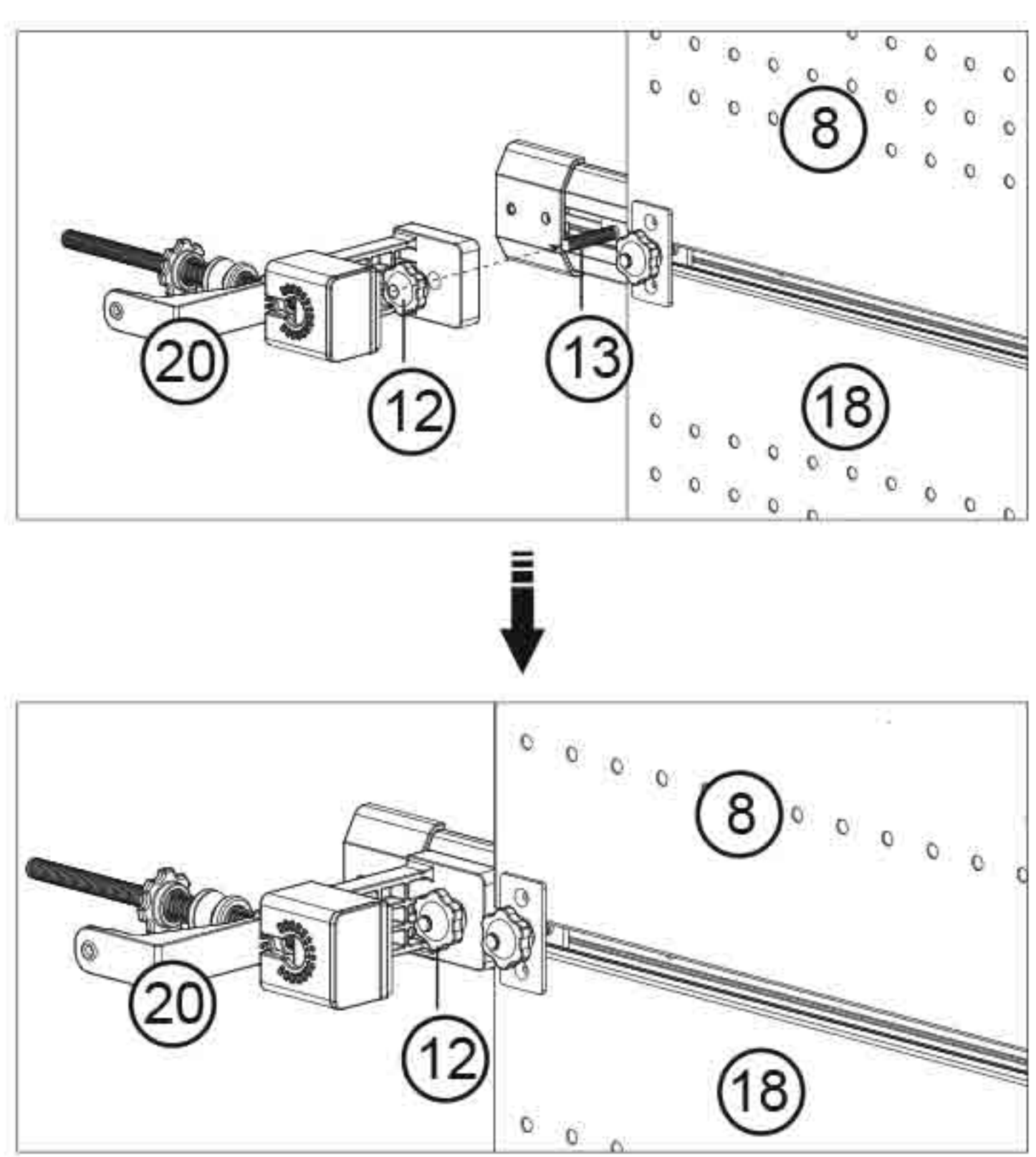

Install option-5 / Option d'installation-5 / Opción de instalación-5

Installation option #5 is similar to #4, but assemble the peg boards to the right of plastic channel.

L'option d'installation #5 est similaire à #4, mais assemblez les planches de cheville à droite du canal en plastique.

La opción de instalación # 5 es similar a # 4, pero ensamble las placas de clavijas a la derecha del canal de plástico.

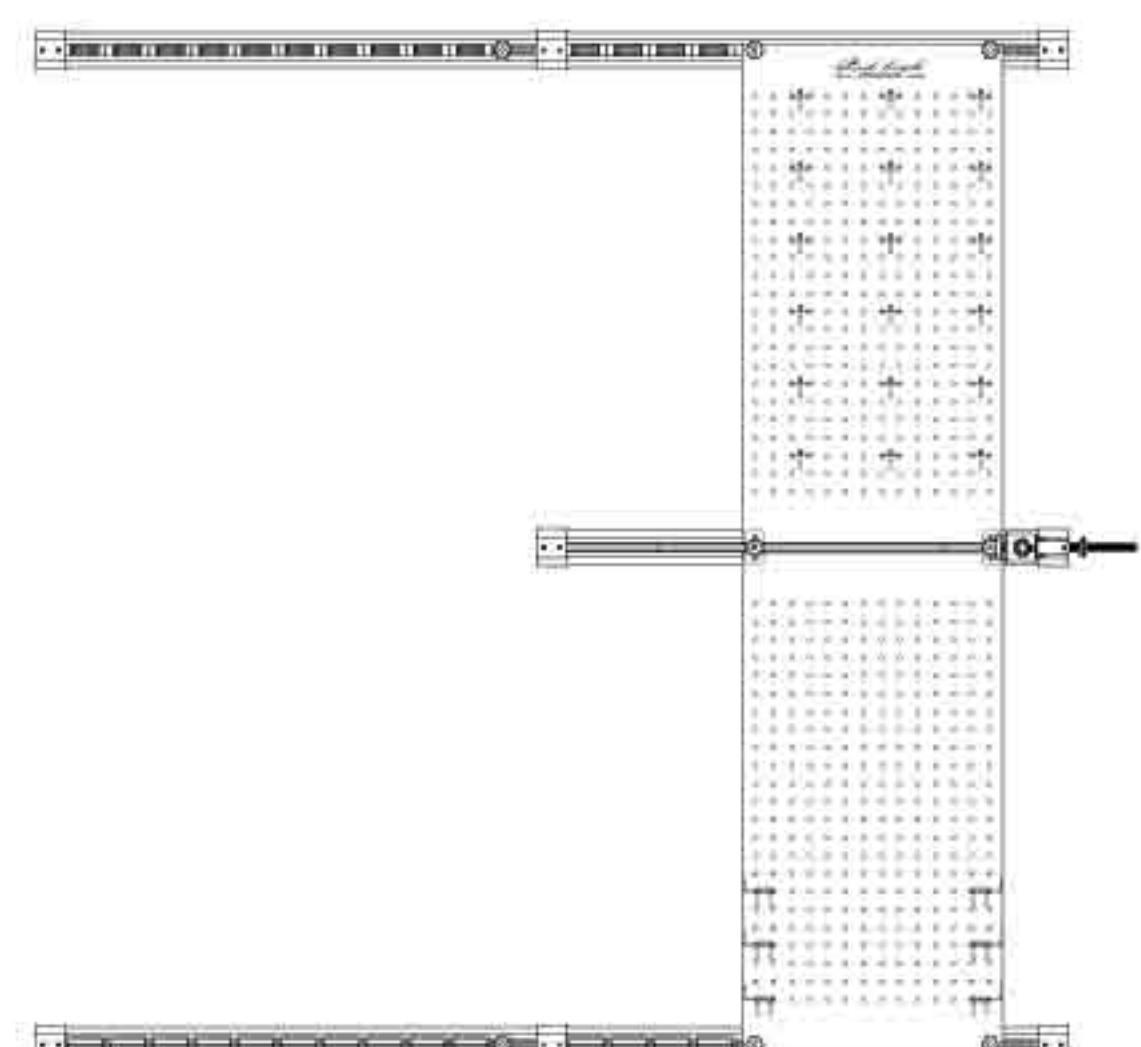
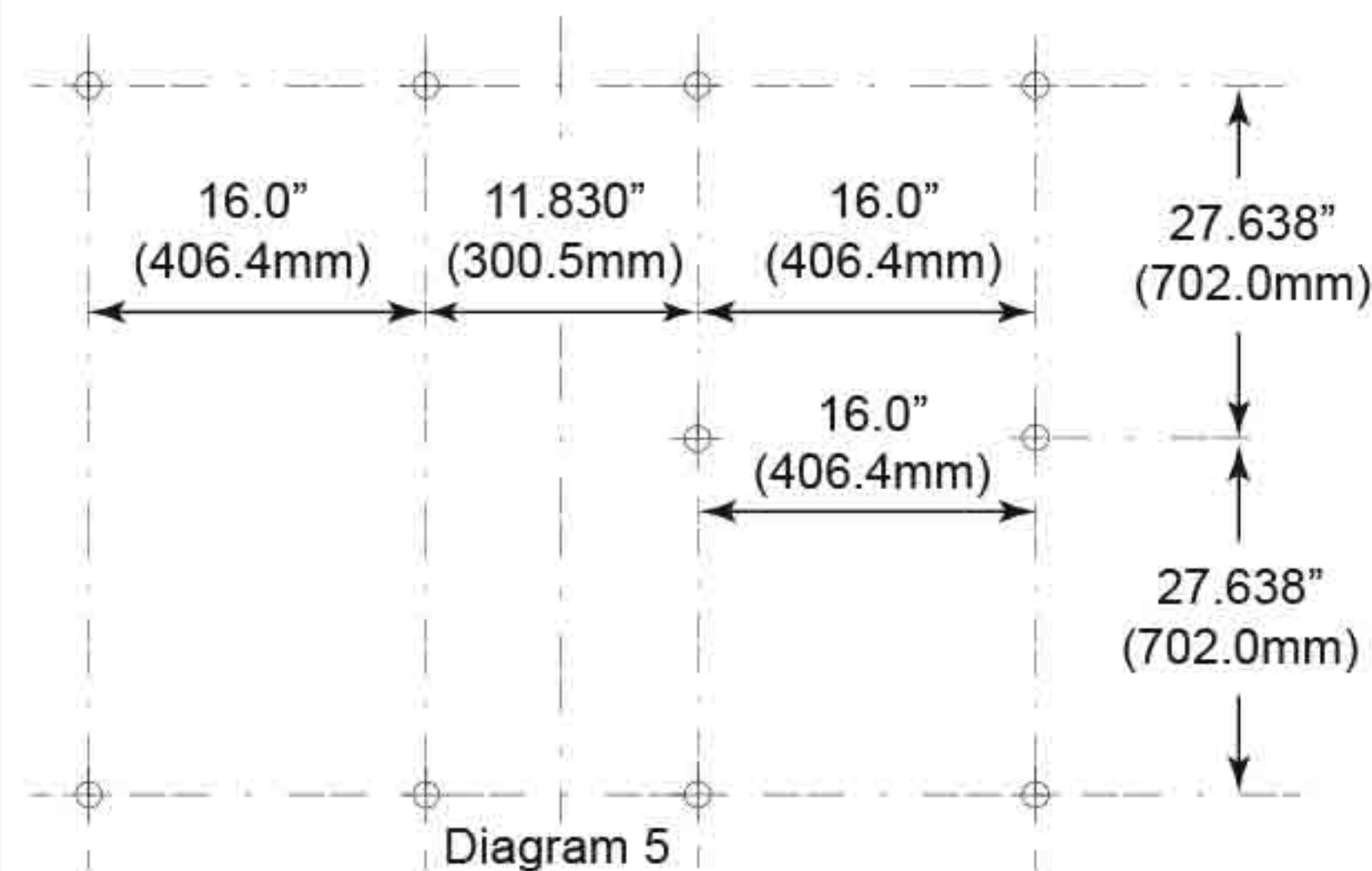

Install option-6 / Option d'installation-6 / Opción de instalación-6

Drill the mounting holes in the wall according to the diagram 6. Refer to Option 4 - steps 2, 3, 4, 5, 6, 8, 9. For Step 7: Attach bottom peg board (#18) on the plastic channel (#1) with 2 M6 square head bolts (#13) go through peg hook holes.

Percer les trous de montage dans le mur selon le diagramme 6. Référez-vous à l'option 4 - étapes 2, 3, 4, 5, 6, 8, 9. Étape 7: Fixez le panneau de cheville inférieur (# 18) sur le canal en plastique (# 1) avec 2 boulons de tête carrés M6 (# 13) passez par des trous de crochet de cheville.

Perforar los orificios de montaje en la pared de acuerdo con el diagrama 6. Consulte la opción 4: pasos 12, 3, 4, 5, 6, 8, 9. Paso 7: Coloque la placa de clavija inferior (# 18) en el canal de plástico con 2 pernos de cabeza cuadrada M6 (# 13) pase por los orificios del gancho de clavijas.

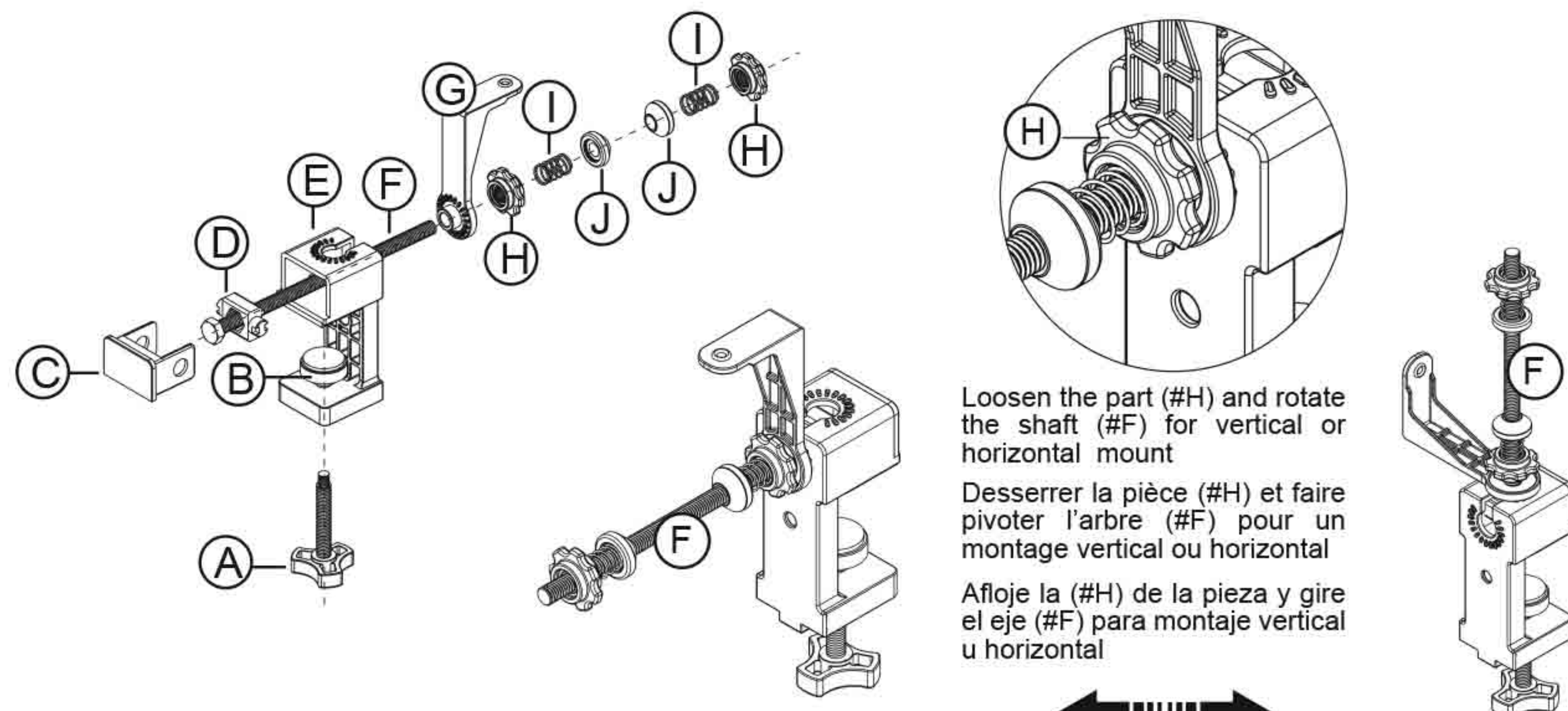
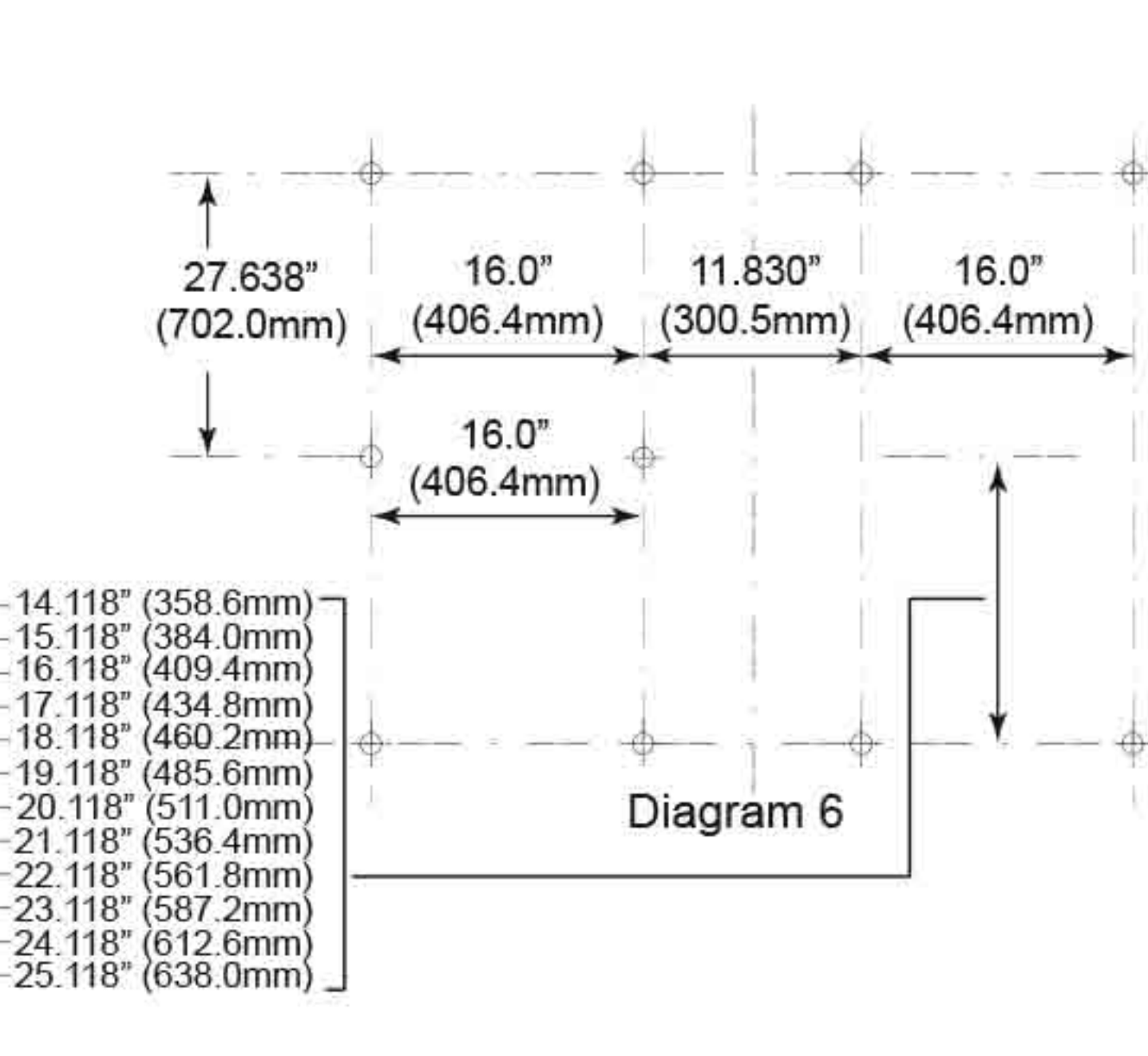
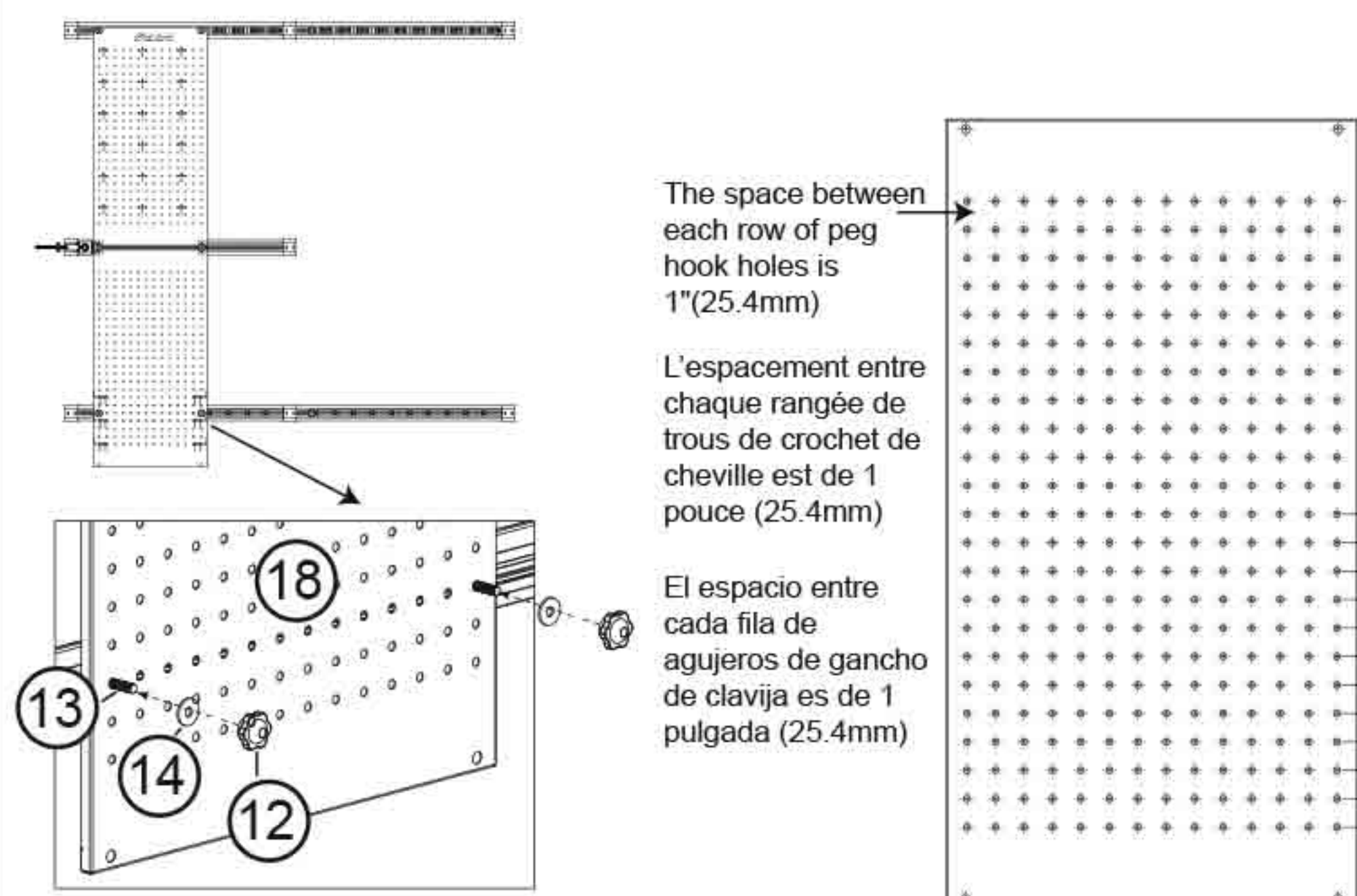

Loosen the part (#H) and rotate the shaft (#F) for vertical or horizontal mount

Desserrer la pièce (#H) et faire pivoter l'arbre (#F) pour un montage vertical ou horizontal

Aloje la (#H) de la pieza y gire el eje (#F) para montaje vertical u horizontal

Install option A - on table top

Option d'installation A - Dessus de table

instalar la opción A - Tablero de mesa

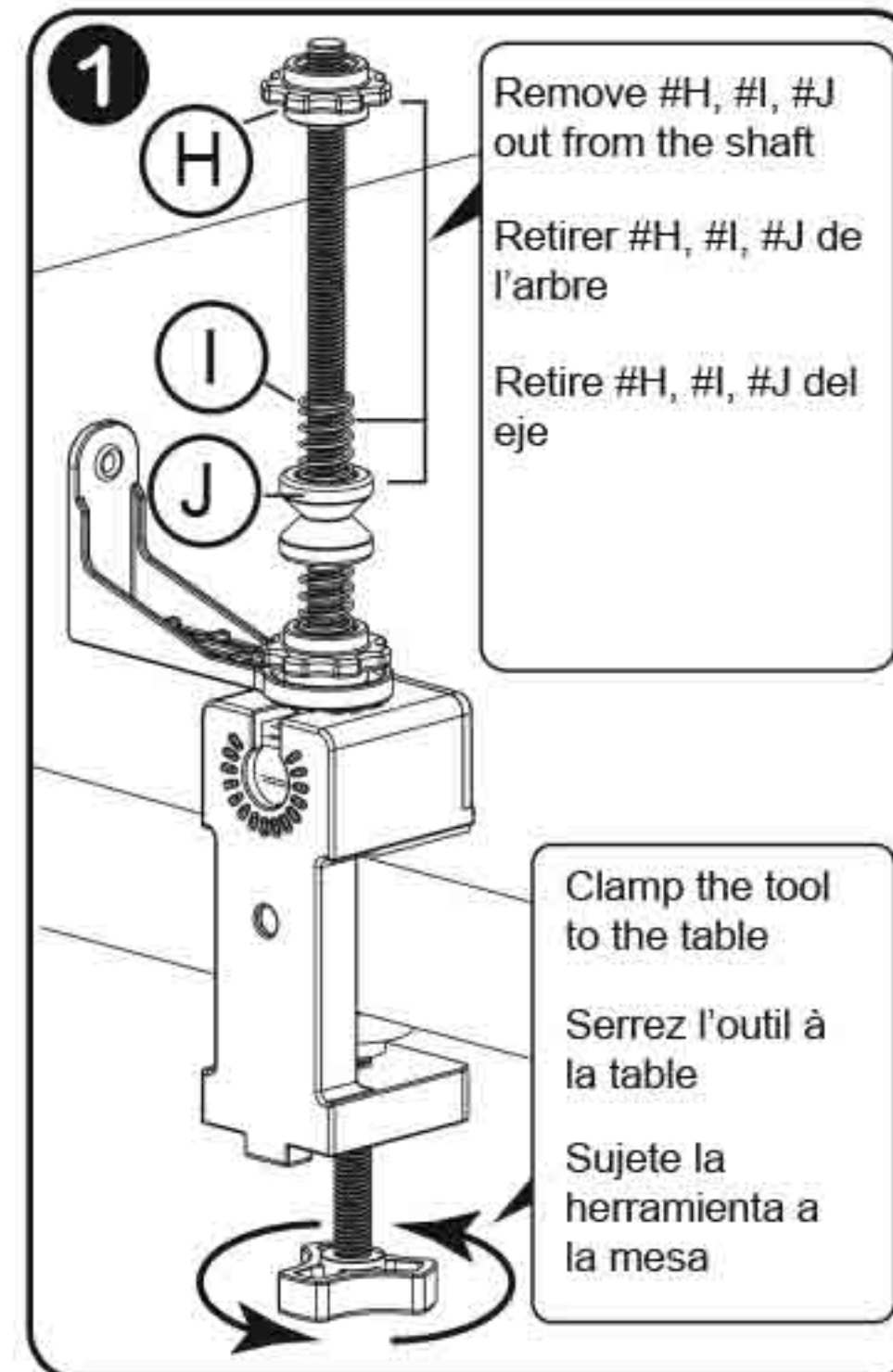

Remove #H, #I, #J out from the shaft  
Retirer #H, #I, #J de l'arbre  
Retire #H, #I, #J del eje

Clamp the tool to the table  
Serrez l'outil à la table  
Sujete la herramienta a la mesa

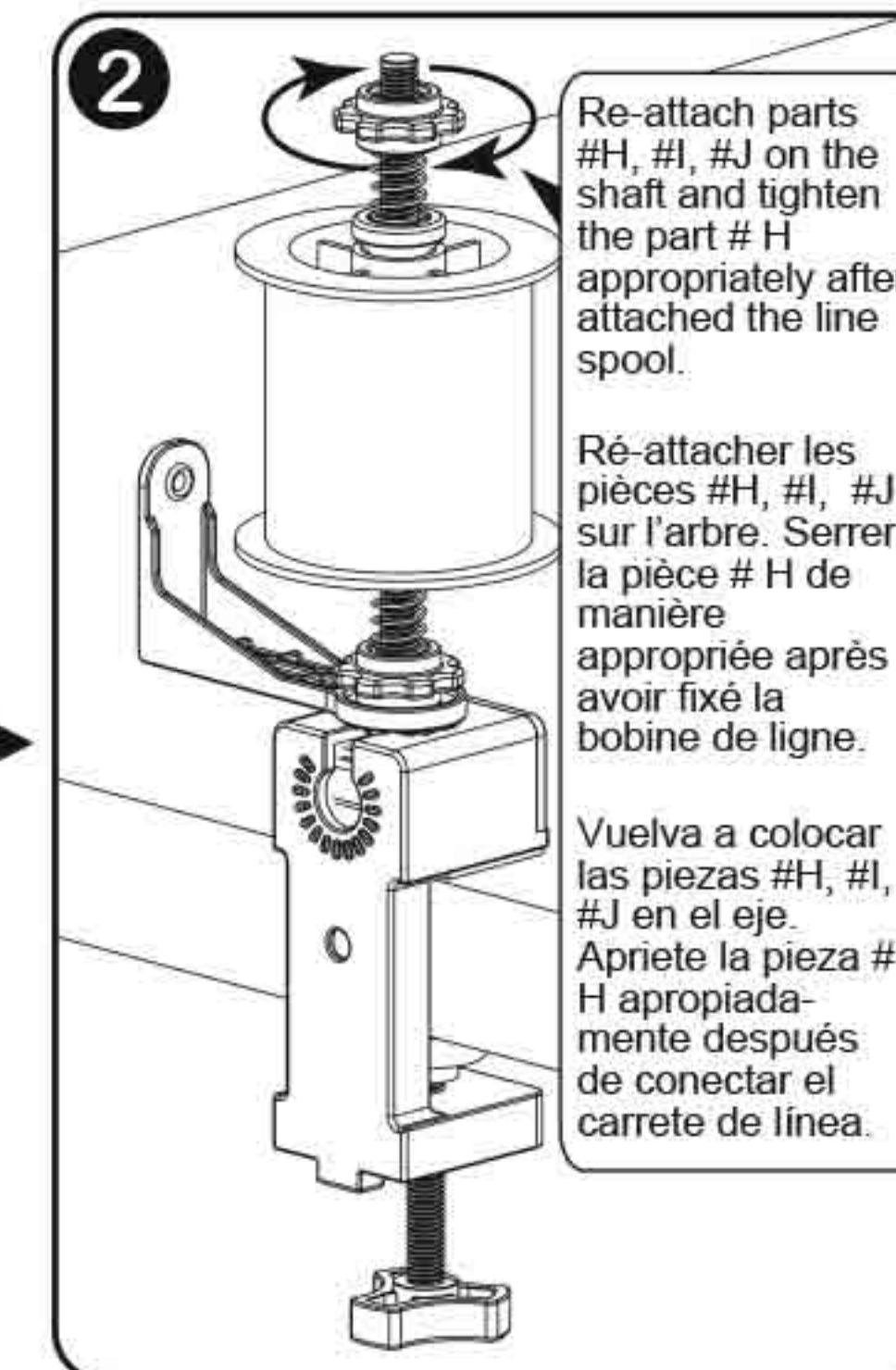

Re-attach parts #H, #I, #J on the shaft and tighten the part #H appropriately after attached the line spool.

Ré-attacher les pièces #H, #I, #J sur l'arbre. Serrer la pièce #H de manière appropriée après avoir fixé la bobine de ligne.

Vuelva a colocar las piezas #H, #I, #J en el eje. Apriete la pieza #H apropiadamente después de conectar el carrete de línea.

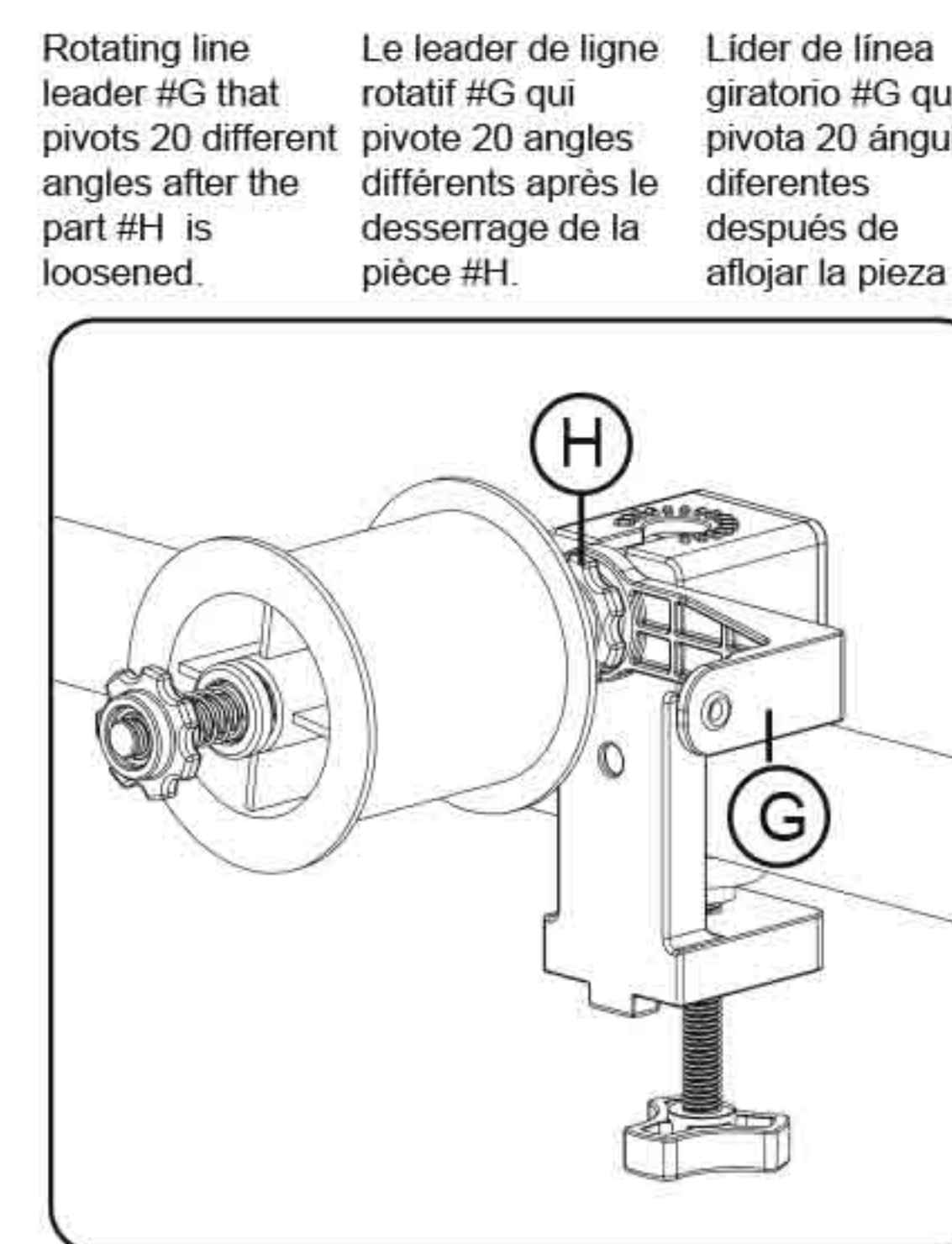

Rotating line leader #G that pivots 20 different angles after the part #H is loosened.

Le leader de ligne rotatif #G qui pivote 20 angles différents après le desserrage de la pièce #H.

Líder de línea giratorio #G que pivota 20 ángulos diferentes después de aflojar la pieza

shaft vertical mount / montage vertical de l'arbre / Montaje vertical del eje

Shaft horizontal mount / montage horizontal de l'arbre / Montaje horizontal del eje

Install option B - On plastic channel

Option d'installation B - Sur canal en plastique

Instalar la opción B - En canal de plástico

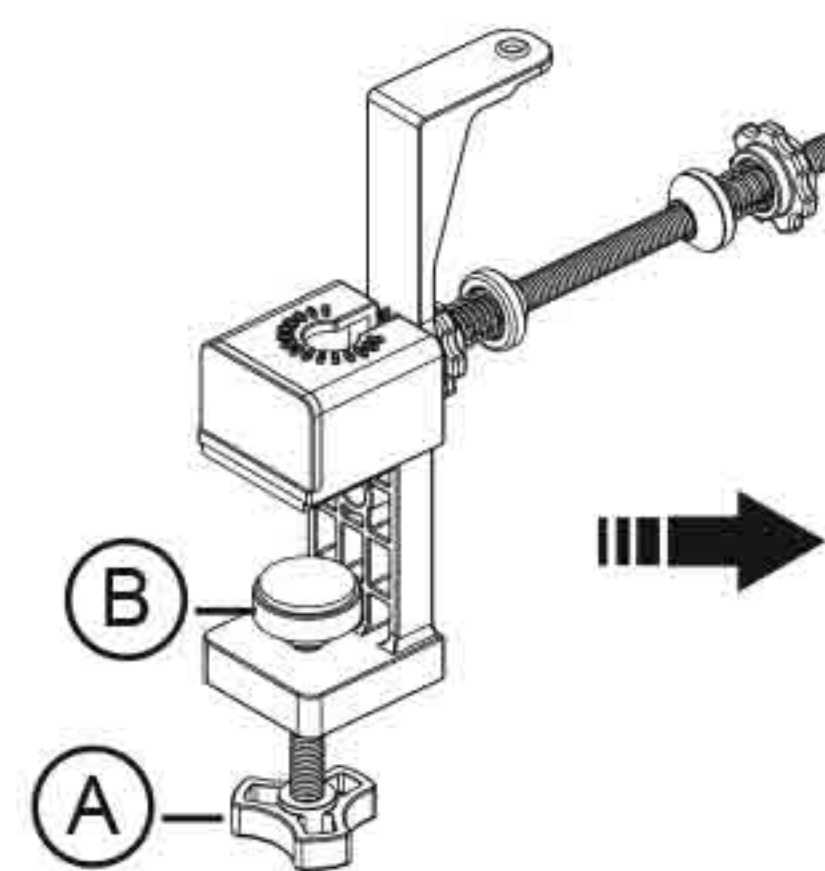

Remove the part #A and #B for fix the spooler on the plastic channel #1 with part #12 and #13.

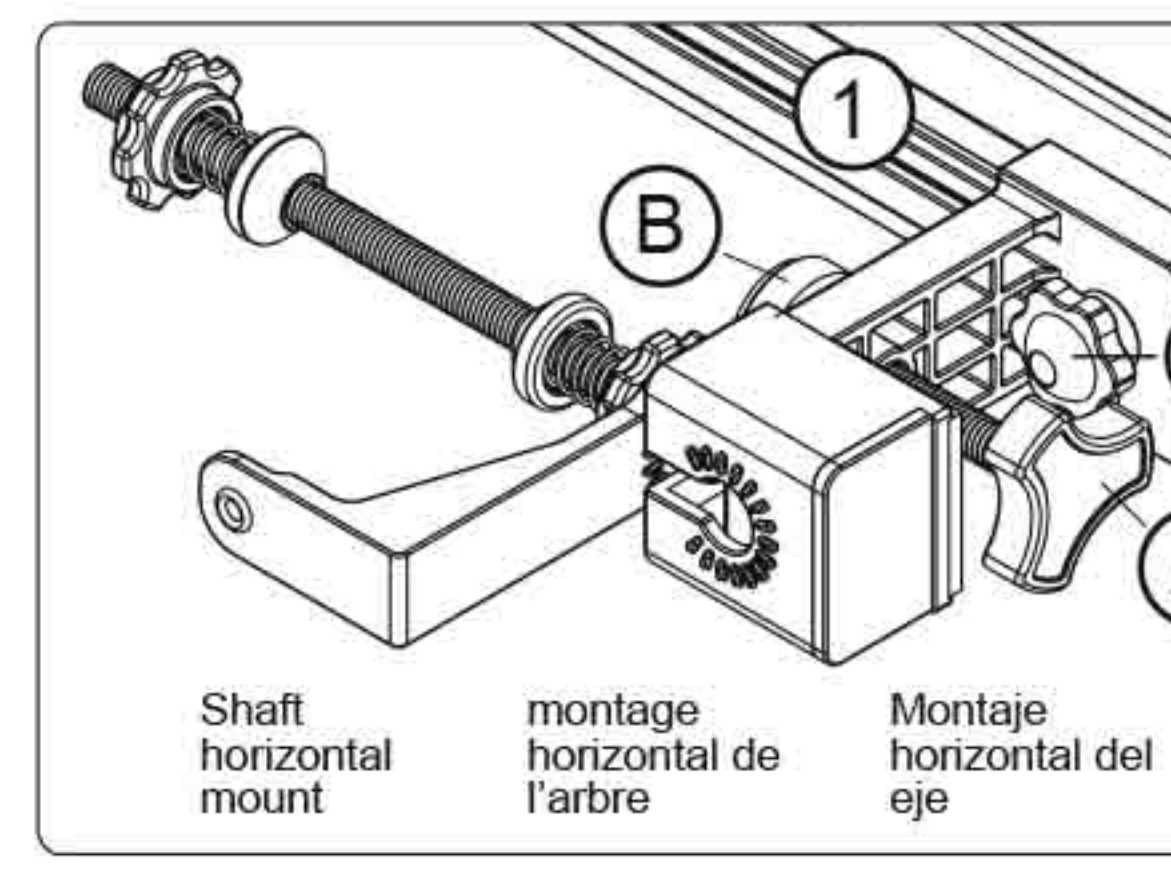

Retirez la pièce #A et #B, Fixez le spouleur sur le canal en plastique (#1) avec les pièces #12 et #13

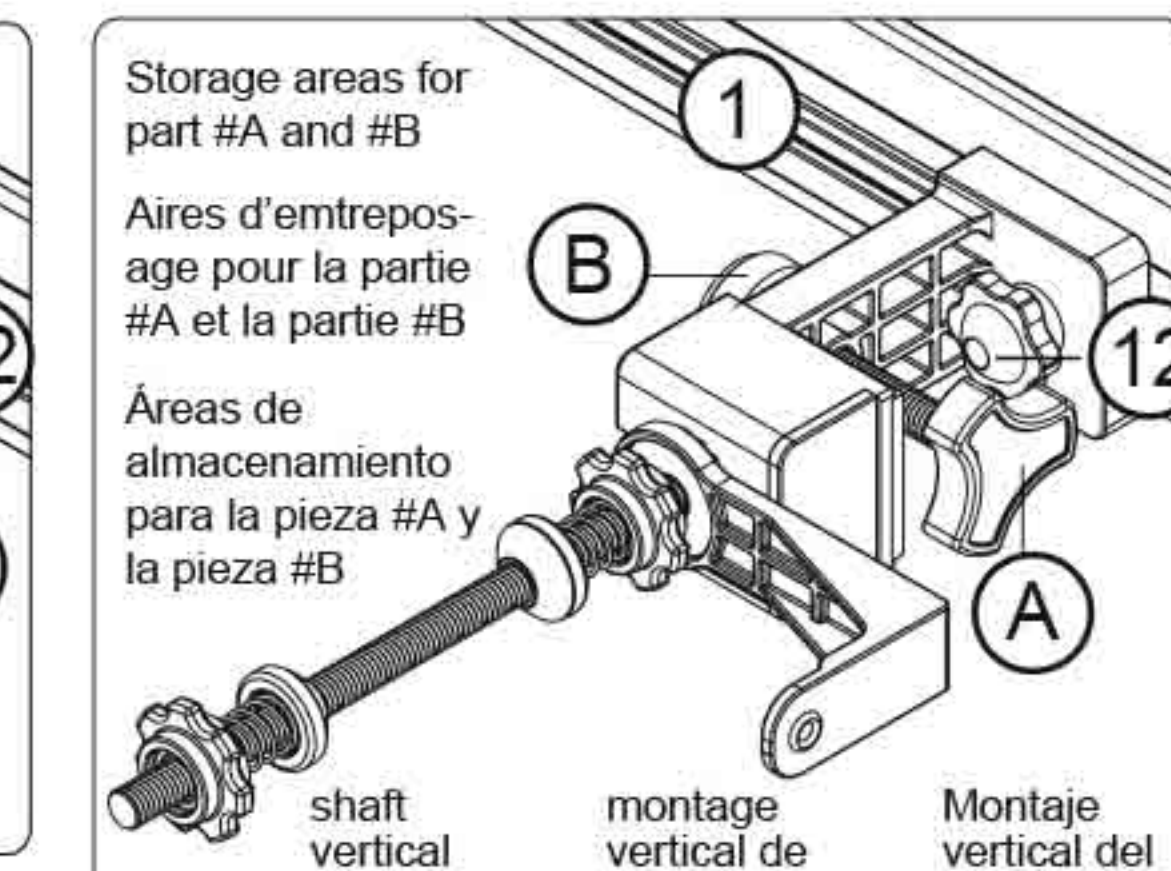

Storage areas for part #A and #B

Aires d'emtreposage pour la partie #A et la partie #B

Áreas de almacenamiento para la pieza #A y la pieza #B

shaft vertical mount / montage vertical de l'arbre / Montaje vertical del eje

shaft horizontal mount / montage horizontal de l'arbre / Montaje horizontal del eje

Retire la parte #A y #B, Conecte la bobina en el canal de plástico (#1) con la parte #12 y #13